

Hexagonal bore - Non-relubricatable

Diámetro interior / centro hexagonal - No relubricable

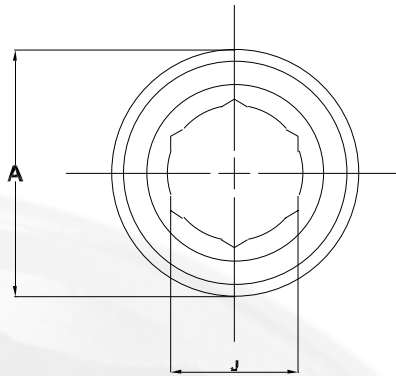
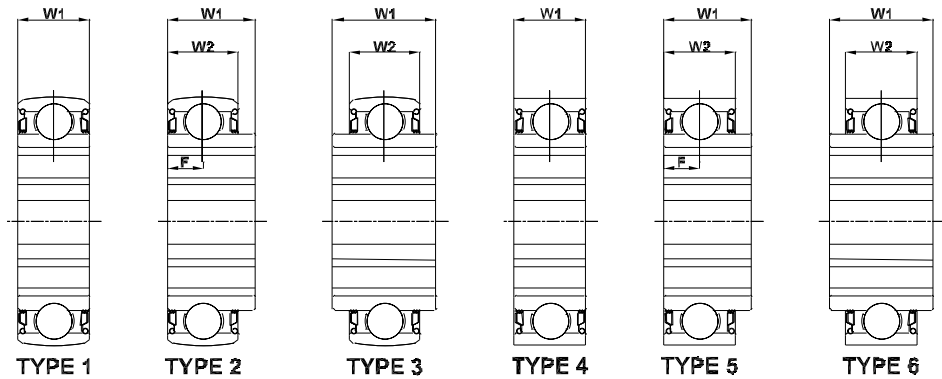

- Type 1 Spherical outer ring
- Type 2 Spherical outer ring - Inner ring extended one side
- Type 3 Spherical outer ring - Inner ring extended both sides
- Type 4 Cylindrical outer ring
- Type 5 Cylindrical outer ring - Inner ring extended one side
- Type 6 Cylindrical outer ring - Inner ring extended both sides

-
- Tipo 1 Anillo exterior esférico
 - Tipo 2 Anillo exterior esférico - anillo interior extendido por un lado
 - Tipo 3 Anillo exterior esférico - anillo interior extendido por ambos lados
 - Tipo 4 Anillo exterior cilíndrico
 - Tipo 5 Anillo exterior cilíndrico- anillo interior extendido por un lado
 - Tipo 6 Anillo exterior cilíndrico- anillo interior extendido por ambos lados



“When the sealed agricultural bearings come prelubricated, there are substantial savings, both in time and money, since the use of these bearings eliminates labor, cost of greasing equipment and cost of bearing replacement”

PFI part number	Type	Notes	I.D. mm (J)	I.D. inch (J)	O.D. mm (A)	W1 mm	W2 mm	Cross reference		Standard packing quantity (SPQ)
205KRRB2 C3	3	Inch size bore	22,25	7/8	52,00	25,40		FAFNIR	205KRRB	20
206KRRB6	3	Inch size bore	25,43	1	62,00	24,00	16,00	FAFNIR	206KRRB6	20
209KRRB2 C3	3	Inch size bore	38,10	1 1/2	85,00	30,00	19,00	FAFNIR	209KRRB2	10
204KRR2 C3	6	Inch size bore	17,65	11/16	47,00	20,96	14,00	FAFNIR	204KRR2	20

“Cuando los rodamientos agrícolas con retenes vienen prelubricados, hay ahorros sustanciales, tanto en tiempo como en dinero, ya que el uso de estos rodamientos elimina la mano de obra, el coste del equipo de engrase y el coste de reemplazar el rodamiento”