



Oil Seals, O-Rings &
Rapid Sleeves

Oil Seals, O-Rings & Rapid Sleeves

Oil Seals	4.1.4
TC Oil Seal Design	4.1.4
How to select an oil seal	4.1.5
Recommended Practice Shaft ISO Limits	4.1.6
Tolerances	4.1.6
Shaft lead-in chamfer to ISO Standards	4.1.6
Shaft Eccentricity	4.1.6
Shaft to Housing Bore Misalignment	4.1.6
Shaft Runout or Whip	4.1.6
Oil Seals - Metric	4.1.7
Oil Seals - Imperial	4.1.10
Oil Seals - TC Cross Reference	4.1.12
Viton Oil Seals - Metric	4.1.17
Viton Oil Seals - Imperial	4.1.19
Automotive Oil Seals - Metric	4.1.20
Automotive Oil Seals - Imperial	4.1.20
Trailer & Caravan Oil Seals	4.1.20
Marine Seals - 2 Piece (Rubber & Stainless Steel)	4.1.20
Road Seals - Metal Cased (TB Style)	4.1.20
O-Rings	4.1.21
BS Series O-Rings (NBR - 70 Duro)	4.1.21
Metric Series O-Rings (NBR - 70 Duro)	4.1.28
BS Series Viton O-Rings (75 Viton)	4.1.35
Metric Series Viton O-Rings (75 Viton)	4.1.42
O-Ring Cord (NBR 70 Duro)	4.1.46
Shaft Repair Sleeves (Metric & Imperial)	4.1.46
V-Ring Seals (NBR & Viton)	4.1.48
VA Series V-Ring Seals (Metric)	4.1.48
VS Series V-Ring Seals (Metric)	4.1.50
VK Seals	4.1.52



TC Oil Seal Design

Finer Power Transmissions stock a large range of Nitrile/Natural Buna Rubber (NBR & Viton) oil seals. These are the most commonly used seals and have excellent resistance to the swelling effects of petroleum oils with a working temperature between -40°C and $+120^{\circ}\text{C}$.

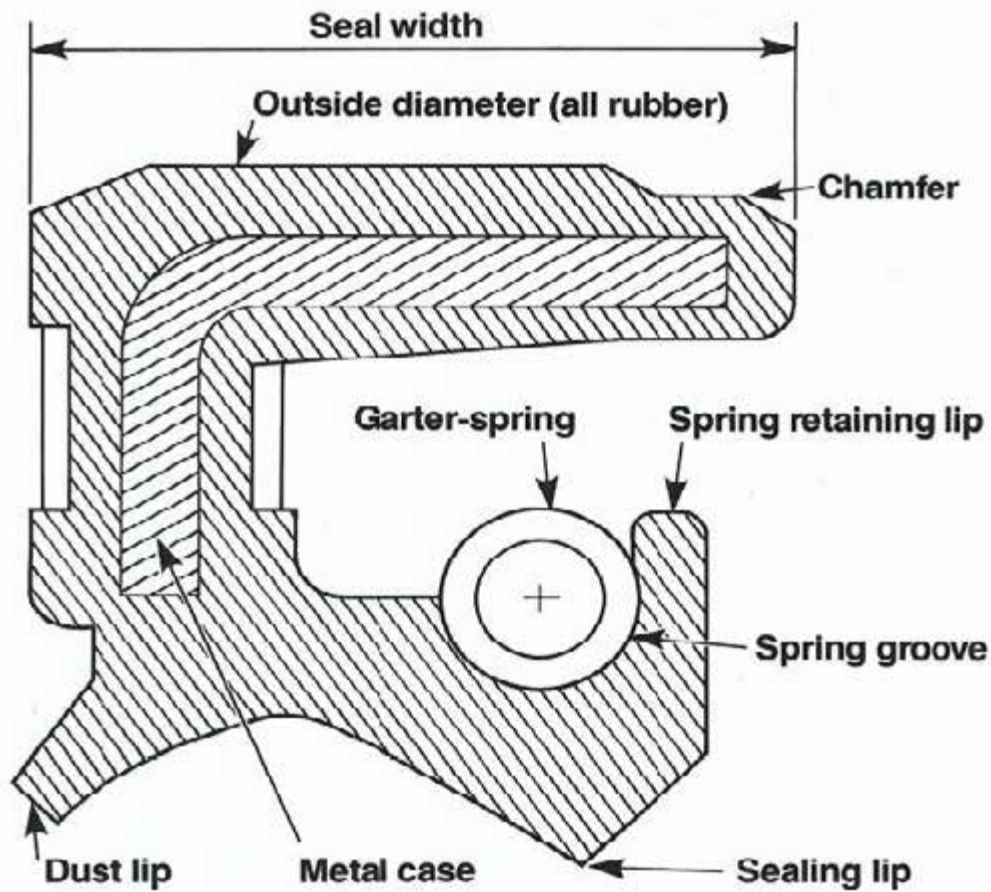

How to select an oil seal

To select the shaft size of an oil seal, the spring lip can be measured and by adding the expected interference with the shaft (using below graph), an estimation of the shaft size can be made.

An allowance must be made for seal lip wear. A heavily worn lip can end up the same as the shaft size. Each application must be considered on its own circumstances.

Interference Levels (mm)

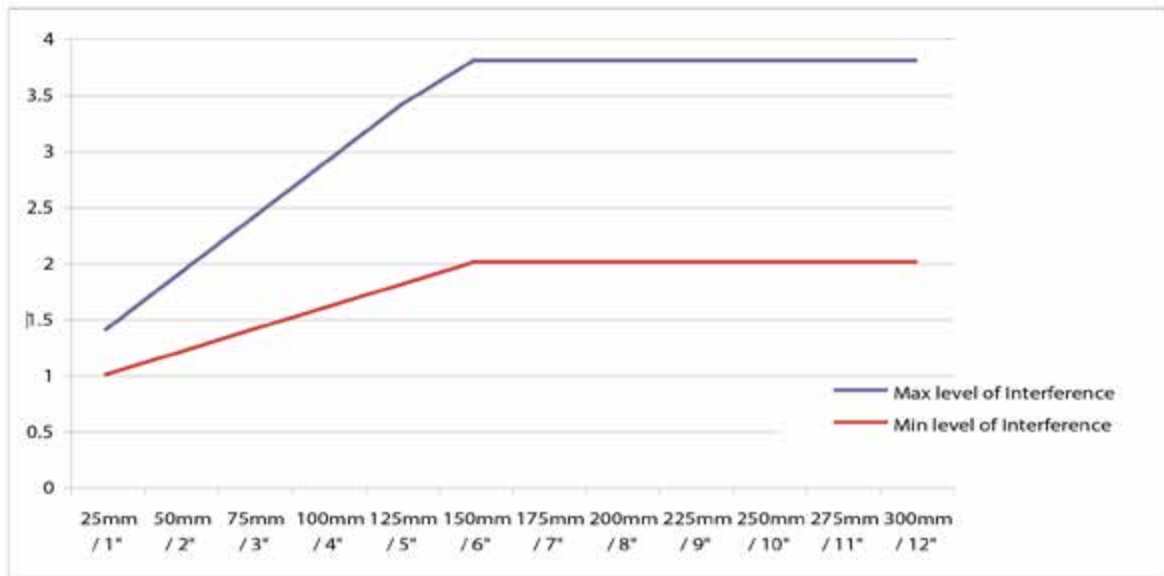

Eg - The spring lip measures 48.5mm and does not appear to be heavily worn, the shaft diameter would be between 49.6mm and 50.3mm ($48.5 + 1.1 = 49.6$, $48.5 + 1.8 = 50.3$). Shaft size is most likely 50mm.

Outside Diameter	Diametrical Tolerance			
	Metal Cased		Rubber Covered	
	mm	Inches	mm	Inches
Under 50mm / 1.968"	+0.20	+0.008	+0.30	+0.012
	+0.08	+0.003	+0.15	+0.006
50mm / 1.968" - 80mm / 3.150"	+0.23	+0.009	+0.35	+0.014
	+0.09	+0.0035	+0.20	+0.008
80mm / 3.150" - 120mm / 4.724"	+0.25	+0.010	+0.35	+0.014
	+0.10	+0.004	+0.20	+0.008
120mm / 4.724" - 180mm / 7.087"	+0.28	+0.011	+0.45	+0.018
	+0.12	+0.005	+0.25	+0.010
180mm / 7.087" - 300mm / 11.811"	+0.35	+0.014	+0.45	+0.018
	+0.15	+0.006	+0.25	+0.010
300mm / 11.811" - 440mm / 17.323"	+0.45	+0.018	+0.55	+0.022
	+0.20	+0.008	+0.30	+0.012

An oil seal can also be selected by the expected interference of the outside diameter of the seal using this chart.

Eg - A seal with a rubber cover would be made to suit a recess between 49.87 and 50.01 ($50.1 - 0.23 = 49.87$, $50.1 - 0.09 = 50.01$).

Shaft size is most likely 50mm.

If the sample seal does not appear too badly damaged, it can be measured purely by dimensions (inside, outside, width).

Seal widths are not generally critical. A narrower seal will in most cases always replace a wider seal. Wider seals can also replace narrower seals if there is sufficient space in the application to allow it.

Recommended Practice Shaft ISO Limits

Tolerances

Shaft diameters should conform to the tolerance bands of ISO h.11.

Relative to the application, departures from roundness of shafts must be kept as low as practicable.

Shaft lead-in chamfer to ISO Standards.

If a shaft lead-in chamfer is used, it cannot be less than $d_1 - d_2$ diametral difference in the table below.

d1 (mm)	d1-d2 (mm)
Up to 10	1.5
11-20	2
21-30	2.5
31-40	3
41-50	3.5
51-70	4
71-95	4.5
96-130	5.5
131-240	7
241-400	11

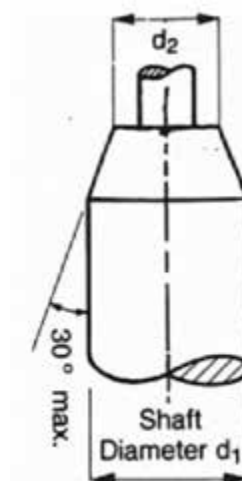

Shaft Eccentricity

Shaft should run in true concentricity with the bore of the housing. When this cannot be assured, eccentricity must be kept to a minimum. Due to inertia, excessive eccentricity may cause the sealing lip to lift at high surface speeds resulting in leakage.

Ideally the seal will be located next to a bearing and bearing play should be minimized.

Eccentricity appears in two forms and may unfavorably affect the seal.

Shaft to Housing Bore Misalignment

Errors machining or excessive build-up of adverse tolerances can cause excessive wear on one side of sealing lip because of unilateral loading of lip.

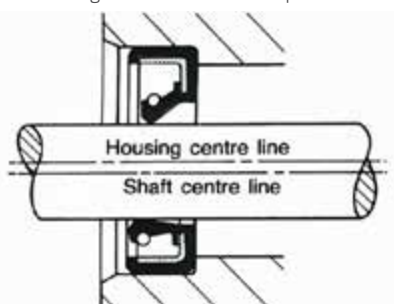

Shaft Runout or Whip

This is when the geometric axis does not coincide with the axis of rotation which may cause lift in the bearing due to wear, flexing of the shaft due to imbalance and excessive overhang or overloading. These conditions may extremely impair the effectiveness of the seal. When operating at high speeds the rate of recovery of the seal lip may not be sufficient to maintain constant contact with the shaft.

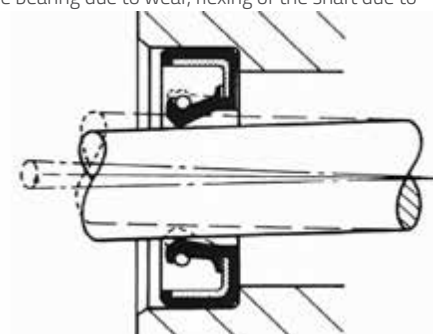

Oil Seals - Metric

5 x 18 x 7TC	13 x 25 x 7TC	17 x 30 x 7TC	20 x 45 x 7TC	25 x 45 x 8TC	30 x 45 x 7TC
6 x 16 x 7TC	13 x 26 x 7TC	17 x 32 x 7TC	20 x 47 x 7TC	25 x 47 x 7TC	30 x 45 x 8TC
6 x 19 x 7TC	13 x 27 x 7TC	17 x 35 x 7TC	20 x 48 x 7TC	25 x 48 x 8TC	30 x 46 x 7TC
6 x 22 x 7TC	13 x 28 x 7TC	17 x 36 x 7TC	20 x 50 x 7TC	25 x 50 x 8TC	30 x 47 x 7TC
6 x 24 x 7TC	13 x 30 x 7TC	17 x 37 x 7TC	20 x 52 x 7TC	25 x 52 x 7TC	30 x 48 x 7TC
7 x 22 x 7TC	13 x 35 x 7TC	17 x 38 x 7TC	22 x 32 x 7TC	25 x 55 x 8TC	30 x 50 x 8TC
8 x 16 x 7TC	14 x 22 x 7TC	17 x 40 x 8TC	22 x 35 x 7TC	25 x 60 x 8TC	30 x 52 x 7TC
8 x 18 x 7TC	14 x 24 x 7TC	17 x 45 x 7TC	22 x 36 x 7TC	25 x 62 x 8TC	30 x 55 x 8TC
8 x 19 x 7TC	14 x 25 x 7TC	17 x 46 x 7TC	22 x 37 x 7TC	26 x 37 x 7TC	30 x 56 x 10TC
8 x 22 x 7TC	14 x 26 x 7TC	17 x 47 x 8TC	22 x 38 x 7TC	26 x 40 x 7TC	30 x 58 x 10TC
8 x 24 x 7TC	14 x 27 x 7TC	18 x 28 x 7TC	22 x 40 x 8TC	26 x 42 x 8TC	30 x 60 x 8TC
9 x 18 x 7TC	14 x 28 x 7TC	18 x 30 x 7TC	22 x 42 x 7TC	26 x 45 x 8TC	30 x 62 x 8TC
9 x 22 x 7TC	14 x 30 x 7TC	18 x 32 x 7TC	22 x 43 x 8TC	26 x 47 x 7TC	30 x 65 x 8TC
9 x 24 x 7TC	14 x 32 x 7TC	18 x 33 x 7TC	22 x 45 x 7TC	27 x 37 x 7TC	30 x 68 x 8TC
9 x 26 x 7TC	14 x 35 x 7TC	18 x 35 x 7TC	22 x 47 x 7TC	27 x 40 x 7TC	30 x 70 x 8TC
9 x 28 x 8TC	15 x 24 x 7TC	18 x 36 x 7TC	22 x 48 x 8TC	27 x 41 x 7TC	30 x 72 x 8TC
10 x 18 x 7TC	15 x 25 x 7TC	18 x 37 x 7TC	22 x 50 x 8TC	27 x 42 x 8TC	31 x 50 x 8TC
10 x 19 x 7TC	15 x 26 x 7TC	18 x 38 x 7TC	22 x 52 x 7TC	27 x 43 x 9TC	32 x 42 x 8TC
10 x 20 x 7TC	15 x 28 x 7TC	18 x 40 x 7TC	23 x 35 x 7TC	27 x 45 x 8TC	32 x 44 x 7TC
10 x 22 x 7TC	15 x 30 x 7TC	19 x 30 x 8TC	23 x 37 x 7TC	27 x 47 x 8TC	32 x 45 x 8TC
10 x 24 x 7TC	15 x 32 x 7TC	19 x 32 x 7TC	23 x 40 x 7TC	27 x 48 x 8TC	32 x 46 x 8TC
10 x 25 x 7TC	15 x 33 x 7TC	19 x 35 x 7TC	23 x 42 x 7TC	27 x 52 x 8TC	32 x 47 x 7TC
10 x 26 x 7TC	15 x 35 x 7TC	19 x 36 x 7TC	24 x 34 x 7TC	28 x 38 x 7TC	32 x 48 x 8TC
10 x 28 x 7TC	15 x 36 x 7TC	19 x 37 x 7TC	24 x 35 x 7TC	28 x 40 x 8TC	32 x 50 x 8TC
10 x 30 x 7TC	15 x 37 x 7TC	19 x 38 x 7TC	24 x 37 x 7TC	28 x 42 x 8TC	32 x 52 x 7TC
10 x 35 x 7TC	15 x 38 x 7TC	19 x 40 x 7TC	24 x 38 x 7TC	28 x 43 x 7TC	32 x 54 x 8TC
11 x 22 x 7TC	15 x 40 x 7TC	19 x 42 x 7TC	24 x 40 x 7TC	28 x 45 x 7TC	32 x 55 x 8TC
11 x 26 x 7TC	15 x 42 x 7TC	19 x 45 x 7TC	24 x 42 x 7TC	28 x 45 x 8TC	32 x 56 x 10TC
12 x 21 x 7TC	16 x 24 x 7TC	19 x 47 x 7TC	24 x 45 x 7TC	28 x 47 x 7TC	32 x 58 x 8TC
12 x 22 x 7TC	16 x 26 x 7TC	20 x 28 x 7TC	24 x 47 x 7TC	28 x 48 x 7TC	32 x 60 x 8TC
12 x 23 x 7TC	16 x 28 x 7TC	20 x 30 x 7TC	24 x 50 x 8TC	28 x 50 x 8TC	32 x 62 x 8TC
12 x 24 x 7TC	16 x 30 x 7TC	20 x 32 x 7TC	24 x 52 x 7TC	28 x 52 x 8TC	32 x 65 x 10TC
12 x 25 x 7TC	16 x 32 x 7TC	20 x 32 x 8TC	25 x 35 x 7TC	28 x 55 x 7TC	32 x 78 x 10TC
12 x 26 x 7TC	16 x 35 x 7TC	20 x 34 x 7TC	25 x 36 x 7TC	29 x 40 x 8TC	33 x 45 x 7TC
12 x 27 x 7TC	16 x 36 x 7TC	20 x 35 x 7TC	25 x 37 x 7TC	29 x 50 x 8TC	33 x 50 x 7TC
12 x 28 x 7TC	16 x 37 x 7TC	20 x 36 x 7TC	25 x 38 x 7TC	29 x 52 x 8TC	33 x 52 x 10TC
12 x 30 x 7TC	16 x 38 x 7TC	20 x 37 x 7TC	25 x 39 x 7TC	30 x 40 x 7TC	33 x 55 x 10TC
12 x 32 x 7TC	16 x 40 x 7TC	20 x 38 x 7TC	25 x 40 x 7TC	30 x 41 x 7TC	33 x 56 x 10TC
12 x 35 x 7TC	16 x 45 x 7TC	20 x 40 x 7TC	25 x 42 x 8TC	30 x 42 x 7TC	34 x 44 x 8TC
12 x 37 x 7TC	17 x 26 x 7TC	20 x 40 x 8TC	25 x 43 x 7TC	30 x 43 x 8TC	34 x 46 x 8TC
13 x 20 x 7TC	17 x 28 x 7TC	20 x 42 x 7TC	25 x 44 x 7TC	30 x 44 x 9TC	

Oil Seals - Metric

34 x 48 x 8TC	37 x 59 x 8TC	42 x 52 x 8TC	47 x 62 x 8TC	54 x 72 x 10TC	60 x 110 x 10TC
34 x 50 x 7TC	37 x 60 x 9TC	42 x 55 x 8TC	47 x 65 x 8TC	54 x 74 x 8TC	60 x 130 x 10TC
34 x 52 x 8TC	37 x 62 x 10TC	42 x 56 x 8TC	47 x 70 x 8TC	54 x 81 x 10TC	62 x 80 x 10TC
34 x 54 x 9TC	38 x 50 x 7TC	42 x 58 x 8TC	48 x 60 x 8TC	54 x 82 x 10TC	62 x 82 x 10TC
34 x 55 x 10TC	38 x 52 x 8TC	42 x 60 x 8TC	48 x 62 x 8TC	55 x 67 x 10TC	62 x 85 x 10TC
34 x 58 x 10TC	38 x 54 x 8TC	42 x 62 x 8TC	48 x 65 x 8TC	55 x 68 x 10TC	62 x 90 x 10TC
34 x 62 x 10TC	38 x 55 x 8TC	42 x 65 x 8TC	48 x 68 x 8TC	55 x 70 x 10TC	62 x 95 x 10TC
34 x 72 x 10TC	38 x 56 x 10TC	42 x 67 x 10TC	48 x 70 x 8TC	55 x 72 x 10TC	62 x 100 x 10TC
34 x 75 x 10TC	38 x 58 x 8TC	42 x 68 x 10TC	48 x 72 x 8TC	55 x 75 x 10TC	63 x 82 x 8TC
35 x 42 x 8TC	38 x 60 x 8TC	42 x 70 x 8TC	48 x 74 x 10TC	55 x 78 x 10TC	63 x 85 x 10TC
35 x 45 x 7TC	38 x 62 x 10TC	42 x 72 x 8TC	48 x 75 x 8TC	55 x 80 x 10TC	63 x 90 x 10TC
35 x 46 x 8TC	38 x 65 x 10TC	42 x 75 x 8TC	48 x 80 x 8TC	55 x 82 x 10TC	64 x 80 x 8TC
35 x 47 x 7TC	38 x 68 x 10TC	43 x 56 x 7TC	48 x 82 x 8TC	55 x 85 x 10TC	64 x 85 x 10TC
35 x 48 x 8TC	38 x 70 x 10TC	43 x 60 x 10TC	48 x 85 x 8TC	55 x 90 x 10TC	65 x 80 x 10TC
35 x 50 x 8TC	38 x 72 x 10TC	43 x 64 x 10TC	50 x 62 x 8TC	55 x 95 x 10TC	65 x 82 x 10TC
35 x 52 x 8TC	38 x 74 x 10TC	43 x 66 x 10TC	50 x 65 x 8TC	55 x 100 x 10TC	65 x 85 x 10TC
35 x 54 x 8TC	38 x 75 x 8TC	43 x 69 x 10TC	50 x 67 x 9TC	55 x 120 x 10TC	65 x 88 x 8TC
35 x 55 x 9TC	38 x 80 x 8TC	43 x 73 x 10TC	50 x 68 x 8TC	56 x 70 x 8TC	65 x 90 x 10TC
35 x 56 x 8TC	39 x 62 x 7TC	44 x 58 x 10TC	50 x 69 x 10TC	56 x 72 x 8TC	65 x 92 x 10TC
35 x 57 x 10TC	39 x 63 x 7TC	44 x 60 x 7TC	50 x 70 x 8TC	56 x 78 x 10TC	65 x 95 x 10TC
35 x 58 x 10TC	39 x 65 x 10TC	44 x 61 x 8TC	50 x 72 x 8TC	56 x 80 x 8TC	65 x 100 x 10TC
35 x 60 x 8TC	40 x 50 x 8TC	44 x 62 x 8TC	50 x 74 x 10TC	56 x 85 x 8TC	65 x 105 x 10TC
35 x 62 x 8TC	40 x 52 x 8TC	44 x 65 x 8TC	50 x 75 x 10TC	57 x 85 x 7TC	65 x 110 x 10TC
35 x 65 x 8TC	40 x 54 x 7TC	44 x 72 x 10TC	50 x 78 x 10TC	58 x 72 x 8TC	65 x 115 x 12TC
35 x 68 x 10SC	40 x 55 x 8TC	45 x 55 x 7TC	50 x 80 x 10TC	58 x 74 x 10TC	65 x 120 x 10TC
35 x 70 x 8TC	40 x 56 x 8TC	45 x 58 x 7TC	50 x 82 x 8TC	58 x 75 x 10TC	65 x 140 x 10TC
35 x 72 x 8TC	40 x 58 x 8TC	45 x 60 x 8TC	50 x 85 x 10TC	58 x 80 x 8TC	67 x 85 x 10TC
35 x 75 x 8TC	40 x 60 x 8TC	45 x 62 x 8TC	50 x 90 x 10TC	58 x 85 x 10TC	67 x 89 x 10TC
35 x 77 x 9TC	40 x 62 x 8TC	45 x 65 x 8TC	50 x 95 x 13TC	58 x 90 x 10TC	68 x 85 x 10TC
35 x 80 x 8TC	40 x 65 x 8TC	45 x 67 x 10TC	50 x 110 x 10TC	60 x 70 x 10TC	68 x 88 x 9TC
36 x 47 x 7TC	40 x 68 x 8TC	45 x 68 x 8TC	52 x 68 x 8TC	60 x 72 x 10TC	68 x 90 x 10TC
36 x 48 x 7TC	40 x 70 x 8TC	45 x 70 x 10TC	52 x 69 x 8TC	60 x 74 x 10TC	68 x 100 x 10TC
36 x 50 x 7TC	40 x 72 x 8TC	45 x 72 x 8TC	52 x 70 x 8TC	60 x 75 x 8TC	70 x 85 x 10TC
36 x 52 x 8TC	40 x 73 x 8TC	45 x 75 x 10TC	52 x 72 x 10TC	60 x 78 x 10TC	70 x 87 x 10TC
36 x 54 x 8TC	40 x 75 x 8TC	45 x 80 x 10TC	52 x 75 x 10TC	60 x 80 x 10TC	70 x 88 x 10TC
36 x 58 x 10TC	40 x 80 x 10TC	45 x 85 x 10TC	52 x 80 x 10TC	60 x 82 x 10TC	70 x 90 x 10TC
36 x 60 x 8TC	40 x 85 x 8TC	45 x 90 x 8TC	52 x 85 x 10TC	60 x 85 x 8TC	70 x 92 x 10TC
36 x 62 x 8TC	40 x 90 x 8TC	45 x 100 x 10TC	52 x 90 x 10TC	60 x 90 x 10TC	70 x 95 x 10TC
36 x 72 x 9TC	41 x 55 x 8TC	46 x 64 x 8TC	53 x 68 x 10TC	60 x 95 x 10TC	70 x 100 x 10TC
37 x 50 x 10TC	41 x 56 x 7TC	46 x 72 x 10TC	54 x 68 x 10TC	60 x 100 x 10TC	70 x 105 x 10TC
37 x 52 x 7TC	41 x 58 x 9TC	46 x 78 x 10TC	54 x 70 x 10TC	60 x 105 x 10TC	70 x 110 x 10TC

Oil Seals - Metric

70 x 112 x 10TC	85 x 100 x 10TC	100 x 125 x 12TC	120 x 165 x 12TC	150 x 180 x 15TC	210 x 250 x 15TC
70 x 115 x 13TC	85 x 105 x 10TC	100 x 130 x 12TC	120 x 170 x 15TC	150 x 190 x 15TC	215 x 240 x 12TC
70 x 125 x 13TC	85 x 110 x 10TC	100 x 135 x 12TC	120 x 180 x 15TC	150 x 200 x 15TC	215 x 250 x 16TC
70 x 150 x 13TC	85 x 115 x 13TC	100 x 140 x 13TC	120 x 215 x 15TC	150 x 210 x 15TC	220 x 250 x 15TC
72 x 88 x 8TC	85 x 120 x 12TC	100 x 150 x 13TC	120 x 260 x 15TC	150 x 225 x 15TC	220 x 255 x 16TC
72 x 90 x 10TC	85 x 125 x 12TC	100 x 180 x 13TC	125 x 143 x 13TC	155 x 180 x 15TC	220 x 260 x 14TC
72 x 95 x 10TC	85 x 130 x 13TC	105 x 125 x 13TC	125 x 145 x 15TC	155 x 190 x 15TC	220 x 270 x 15TC
72 x 100 x 10TC	85 x 140 x 12TC	105 x 130 x 12TC	125 x 150 x 12TC	155 x 200 x 15TC	225 x 250 x 15TC
72 x 105 x 13TC	85 x 150 x 12TC	105 x 135 x 12TC	125 x 155 x 12TC	160 x 180 x 13TC	230 x 260 x 15TC
73 x 100 x 10TC	85 x 180 x 12TC	105 x 140 x 12TC	125 x 160 x 12TC	160 x 185 x 13TC	230 x 265 x 15TC
75 x 90 x 10TC	88 x 110 x 12TC	105 x 145 x 12TC	125 x 165 x 15TC	160 x 190 x 15TC	230 x 270 x 16TC
75 x 95 x 10TC	88 x 115 x 13TC	105 x 150 x 13TC	125 x 170 x 15TC	160 x 200 x 15TC	230 x 280 x 15TC
75 x 100 x 10TC	90 x 105 x 12TC	105 x 160 x 13TC	128 x 150 x 13TC	160 x 240 x 15TC	235 x 270 x 16TC
75 x 105 x 10TC	90 x 110 x 12TC	105 x 170 x 12TC	130 x 150 x 12TC	160 x 290 x 15TC	240 x 270 x 15TC
75 x 110 x 10TC	90 x 115 x 13TC	105 x 190 x 13TC	130 x 160 x 15TC	165 x 190 x 12TC	240 x 280 x 15TC
75 x 115 x 12TC	90 x 118 x 12TC	110 x 130 x 12TC	130 x 165 x 15TC	165 x 200 x 15TC	250 x 280 x 15TC
75 x 120 x 12TC	90 x 120 x 12TC	110 x 135 x 12TC	130 x 170 x 15TC	170 x 190 x 13TC	250 x 285 x 15TC
75 x 130 x 13TC	90 x 125 x 12TC	110 x 140 x 12TC	130 x 180 x 15TC	170 x 200 x 15TC	250 x 290 x 15TC
75 x 160 x 13TC	90 x 130 x 13TC	110 x 145 x 12TC	130 x 200 x 15TC	170 x 210 x 15TC	260 x 290 x 15TC
76 x 110 x 13TC	90 x 135 x 12TC	110 x 150 x 12TC	135 x 160 x 15TC	170 x 220 x 16TC	260 x 300 x 18TC
77 x 93 x 10TC	90 x 140 x 12TC	110 x 155 x 12TC	135 x 165 x 15TC	175 x 200 x 15TC	270 x 300 x 15TC
77 x 95 x 10TC	90 x 160 x 12TC	110 x 160 x 13TC	135 x 170 x 15TC	175 x 210 x 15TC	280 x 310 x 15TC
78 x 100 x 10TC	90 x 190 x 12TC	110 x 170 x 13TC	140 x 160 x 13TC	180 x 200 x 15TC	280 x 320 x 18TC
80 x 95 x 8TC	94 x 126 x 12TC	110 x 200 x 13TC	140 x 165 x 15TC	180 x 210 x 15TC	285 x 310 x 16TC
80 x 100 x 10TC	95 x 110 x 12TC	114 x 135 x 13TC	140 x 170 x 15TC	180 x 215 x 15TC	300 x 340 x 18TC
80 x 105 x 10TC	95 x 115 x 12TC	115 x 135 x 12TC	140 x 175 x 15TC	180 x 220 x 16TC	315 x 350 x 15TC
80 x 110 x 10TC	95 x 120 x 12TC	115 x 140 x 12TC	140 x 180 x 15TC	180 x 230 x 15TC	315 x 355 x 16TC
80 x 115 x 13TC	95 x 125 x 12TC	115 x 145 x 13TC	140 x 210 x 15TC	185 x 210 x 15TC	320 x 360 x 18TC
80 x 120 x 13TC	95 x 130 x 13TC	115 x 150 x 12TC	140 x 250 x 15TC	185 x 215 x 16TC	320 x 380 x 25TC
80 x 125 x 12TC	95 x 135 x 13TC	115 x 160 x 12TC	145 x 165 x 15TC	190 x 220 x 15TC	340 x 380 x 20TC
80 x 130 x 13TC	95 x 145 x 13TC	118 x 140 x 13TC	145 x 170 x 14TC	190 x 230 x 15TC	340 x 400 x 25TC
80 x 135 x 12TC	95 x 170 x 13TC	120 x 140 x 13TC	145 x 175 x 15TC	195 x 220 x 15TC	
80 x 140 x 12TC	95 x 200 x 13TC	120 x 145 x 13TC	145 x 180 x 15TC	200 x 230 x 15TC	
80 x 170 x 12TC	98 x 130 x 13TC	120 x 150 x 12TC	150 x 165 x 15TC	200 x 240 x 15TC	
82 x 105 x 13TC	100 x 118 x 12TC	120 x 155 x 12TC	150 x 168 x 13TC	200 x 250 x 15TC	
84 x 100 x 10TC	100 x 120 x 12TC	120 x 160 x 12TC	150 x 170 x 15TC	210 x 240 x 15TC	

Oil Seals - Imperial

Legend: 1000 = 1"

250-625-1875C	750-1812-250TC	1125-1687-250TC	1375-2250-375TC	1625-2562-375TC	1938-2625-375TC
250-750-250TC	750-1875-250TC	1125-1750-375TC	1375-2312-375TC	1625-2625-375SC	1938-2750-375TC
250-1000-250TC	750-1937-375TC	1125-1812-250TC	1375-2375-375TC	1625-2687-375TC	1938-3000-375TC
312-750-250TC	812-1187-250SC	1125-1875-375TC	1375-2437-375TC	1625-2750-375SC	2000-2500-250TC
312-875-250TC	812-1312-250TC	1125-2000-375TC	1375-2500-375TC	1625-2812-375TC	2000-2625-375TC
375-750-250TC	812-1375-250TC	1125-2062-250SC	1375-2687-375TC	1625-2875-375TC	2000-2687-375TC
375-875-250TC	812-1500-375TC	1125-2125-250SC	1375-2750-375TC	1625-2937-375TC	2000-2750-375TC
375-1000-250TC	812-1625-375SC	1125-2250-375SC	1375-2875-375TC	1625-3000-375TC	2000-2875-375TC
375-1062-250TC	812-2000-375TC	1125-2312-375TC	1375-3000-375TC	1687-2500-375TC	2000-2937-375TC
375-1125-250SC	875-1250-250TC	1125-2375-375TC	1437-2125-250TC	1687-2750-375TC	2000-3000-375TC
375-1375-375SC	875-1375-250TC	1125-2437-375TC	1437-2250-375TC	1687-3000-375TC	2000-3062-375TC
375-1500-375TC	875-1500-250TC	1125-2500-375TC	1437-2375-375TC	1750-2250-375TC	2000-3125-375SC
437-875-250TC	875-1500-375TC	1187-1750-250TC	1437-2500-375TC	1750-2312-250TC	2000-3250-375SC
437-1000-250TC	875-1625-375TC	1187-1875-250SC	1500-2000-375TC	1750-2375-375TC	2000-3375-375TC
437-1125-375TC	875-1875-375TC	1187-2000-250TC	1500-2062-250TC	1750-2437-375TC	2000-3500-375SC
500-875-250TC	875-1937-375TC	1250-1625-250TC	1500-2125-375TC	1750-2500-375TC	2000-3625-500TC
500-937-250TC	875-2000-375TC	1250-1687-250TC	1500-2187-375TC	1750-2562-375TC	2000-3750-500TC
500-1000-250TC	937-1375-250TC	1250-1750-250TC	1500-2250-375TC	1750-2625-375TC	2062-2875-375SC
500-1062-250TC	937-1500-250TC	1250-1750-375TC	1500-2375-375TC	1750-2687-375TC	2062-3000-375TC
500-1125-250TC	937-1750-375TC	1250-1875-375TC	1500-2437-375TC	1750-2750-375TC	2125-2750-375TC
500-1375-250TC	1000-1375-250TC	1250-1937-375TC	1500-2500-375TC	1750-2812-375TC	2125-2875-375TC
562-1000-250TC	1000-1437-250TC	1250-2000-375TC	1500-2562-375TC	1750-2875-375TC	2125-3000-375TC
562-1125-250TC	1000-1500-375TC	1250-2062-250SC	1500-2625-375SC	1750-2937-375TC	2125-3062-375SC
562-1250-250SC	1000-1500-250TC	1250-2125-375SC	1500-2687-375TC	1750-3000-375TC	2125-3125-375TC
625-937-250TC	1000-1625-375TC	1250-2187-375TC	1500-2750-375TC	1750-3125-375TC	2125-3250-375TC
625-1000-250TC	1000-1687-250TC	1250-2250-375TC	1500-2812-375TC	1750-3375-375TC	2125-3375-375SC
625-1062-250TC	1000-1750-375TC	1250-2312-375TC	1500-2875-375SC	1750-3500-500TC	2125-3500-375SC
625-1125-250TC	1000-1812-250TC	1250-2375-375SC	1500-2937-375TC	1750-3625-500TC	2187-2562-250TC
625-1250-250TC	1000-1875-250TC	1250-2500-375SC	1500-3000-375TC	1812-2500-375TC	2187-2875-375TC
625-1500-375TC	1000-2000-375TC	1250-2625-375TC	1562-2125-375TC	1812-2625-375TC	2187-3000-375TC
687-1125-250TC	1000-2062-250SC	1250-2750-375TC	1562-2250-375TC	1812-2750-375TC	2187-3250-375TC
687-1250-250TC	1000-2125-250TC	1250-2875-250TC	1562-2375-375TC	1812-2875-375TC	2250-2750-375TC
687-1375-250TC	1000-2187-375TC	1312-2000-250TC	1562-2500-250SC	1812-3000-375TC	2250-2875-375TC
750-1125-250TC	1000-2250-375TC	1312-2125-375TC	1562-2625-375TC	1875-2375-250TC	2250-3000-375TC
750-1187-250TC	1000-2312-375TC	1312-2250-375TC	1562-2750-375TC	1875-2500-375TC	2250-3062-375SC
750-1250-250TC	1000-2500-375TC	1312-2375-375TC	1562-3000-375TC	1875-2625-375TC	2250-3125-375TC
750-1375-250TC	1062-1500-250TC	1312-2500-375TC	1625-2125-375TC	1875-2750-375TC	2250-3187-375TC
750-1375-375TC	1062-1625-250TC	1375-1875-250TC	1625-2187-375TC	1875-2812-375TC	
750-1437-250SC	1062-1750-375TC	1375-2000-375TC	1625-2250-500TC	1875-2875-375TC	
750-1500-375TC	1062-1875-375TC	1375-2062-250TC	1625-2375-375TC	1875-2937-375TC	
750-1625-375TC	1125-1500-250TC	1375-2125-375TC	1625-2437-375TC	1875-3000-375TC	
750-1750-375SC	1125-1625-375SC	1375-2187-375TC	1625-2500-375TC	1875-3125-375TC	

Oil Seals - Imperial

Legend: 1000 = 1"

2250-3250-375SC	2625-3750-375SC	3187-4500-500TC	3750-4875-500TC	4500-5500-500TC	6500-7500-500TC
2250-3375-375TC	2625-3875-500SC	3250-4000-500TC	3750-5000-500TC	4500-5750-500SC	6500-8000-500SC
2250-3500-500TC	2625-4000-500TC	3250-4125-500SC	3750-5625-500TC	4500-6000-500TC	6625-7625-500TC
2250-3625-375TC	2625-4125-500SC	3250-4250-500TC	3812-4875-500TC	4500-6250-500TC	6750-7750-500TC
2250-3625-500TC	2687-3500-375SC	3250-4375-500TC	3875-4625-500TC	4562-5625-500SC	6875-7625-500SC
2250-3750-375SC	2750-3500-375TC	3250-4500-500TC	3875-4750-500SC	4625-5625-500SC	6875-7875-500SC
2313-3125-375SC	2750-3625-375TC	3250-4625-500SC	3875-4875-500TC	4625-5750-500TC	7000-8000-500TC
2313-3187-375TC	2750-3750-375TC	3250-4750-500SC	3875-5000-500SC	4625-6000-500TC	7000-8500-500TC
2313-3375-375TC	2750-3875-375TC	3312-4375-500TC	3875-5250-500TC	4687-5750-500TC	7125-8625-562TC
2375-2875-375TC	2750-4000-500TC	3312-4500-500TC	3875-5375-500TC	4750-5750-500TC	7250-8750-562TC
2375-3000-375TC	2750-4125-500SC	3375-4125-500SC	3875-5687-500TC	4750-6250-500TC	7250-8875-625TC
2375-3062-375SC	2750-4250-500SC	3375-4250-500TC	3937-5000-500TC	4812-5875-500TC	7375-8875-562TC
2375-3125-375TC	2750-4500-500TC	3375-4375-500SC	4000-4750-500TC	4937-6000-500TC	7500-8500-500TC
2375-3250-375SC	2812-3375-375SC	3375-4500-500TC	4000-5000-500TC	5000-5750-500TC	7500-9000-500TC
2375-3250-500TC	2812-3625-375TC	3375-4625-500SC	4000-5125-500TC	5000-6000-500TC	7625-9125-562TC
2375-3375-375TC	2875-3625-375TC	3375-4750-500TC	4000-5250-500TC	5000-6250-500TC	7750-9250-562TC
2375-3500-375TC	2875-3875-375SC	3375-4875-500TC	4000-5375-500TC	5000-6500-500TC	7875-9375-562TC
2375-3500-500TC	2875-4000-500TC	3375-5000-500TC	4000-5500-500TC	5062-6125-500TC	8000-9000-500TC
2375-3625-375SC	2875-4125-500SC	3437-4500-500TC	4000-5625-500TC	5125-6125-500TC	8000-9500-562TC
2375-3750-375TC	2875-4250-500SC	3500-4125-500SC	4000-5750-500TC	5125-6750-500TC	8125-9625-562TC
2437-3250-375TC	2875-4500-500TC	3500-4250-500SC	4062-5125-500SC	5187-6250-500SC	8250-9750-562TC
2437-3625-500TC	2937-3750-375SC	3500-4375-500TC	4125-5000-500TC	5250-6250-500SC	8375-9875-562TC
2500-3000-375TC	3000-3750-375TC	3500-4500-500TC	4125-5125-500SC	5312-6375-500SC	8500-10000-562TC
2500-3062-375TC	3000-3875-375TC	3500-4625-500TC	4187-5250-500SC	5375-6375-500SC	8625-10125-562TC
2500-3187-375TC	3000-4000-500TC	3500-4750-500TC	4187-5875-500TC	5437-6500-500SC	8750-10250-562TC
2500-3250-375TC	3000-4125-500SC	3500-4875-500SC	4250-5000-500TC	5500-6500-500TC	8875-10375-562TC
2500-3375-375SC	3000-4250-500SC	3500-5000-500TC	4250-5250-500TC	5562-6625-500TC	9000-10000-625TC
2500-3500-375TC	3000-4375-500TC	3500-5250-500TC	4250-5500-500TC	5625-7000-500TC	9000-10500-562TC
2500-3625-375TC	3000-4500-500TC	3562-4625-500SC	4250-5625-500SC	5625-7500-500TC	9125-10625-562TC
2500-3750-375TC	3000-4625-500SC	3625-4375-500TC	4250-5750-500TC	5687-6750-500SC	9250-10750-562TC
2500-3875-500TC	3000-4750-500SC	3625-4500-500SC	4250-6000-500TC	5750-6750-500TC	9375-10875-562TC
2500-4000-500TC	3000-5000-500TC	3625-4625-500TC	4250-6250-500TC	5812-6875-500TC	9500-11000-562TC
2500-4125-500SC	3062-4125-500SC	3625-4750-500TC	4312-5375-500SC	5875-6875-500TC	9625-11125-562TC
2562-3375-375SC	3125-3875-375SC	3625-5000-500TC	4375-5250-500TC	5937-7000-500TC	9750-11250-562TC
2562-3500-500TC	3125-4000-500TC	3625-5250-500SC	4375-5375-500TC	6000-7000-500TC	9875-11375-562TC
2562-3750-500TC	3125-4250-500SC	3687-4750-500TC	4375-5750-500TC	6000-7187-625TC	10000-11500-562TC
2625-3125-375SC	3125-4375-500SC	3687-5625-500TC	4375-6000-500TC	6000-7500-500TC	
2625-3250-375SC	3125-4500-500TC	3750-4375-500SC	4375-6250-500TC	6125-7125-500TC	
2625-3375-375TC	3125-4625-500TC	3750-4500-500SC	4437-5500-500SC	6250-7000-500TC	
2625-3500-375SC	3125-4750-500TC	3750-4625-500SC	4500-5250-500TC	6250-7250-500TC	
2625-3625-375TC	3187-4250-500TC	3750-4750-500TC	4500-5375-500SC	6375-7375-500SC	

Oil Seals - TC Cross Reference

TC12001	250-750-250TC	TC12046	1125-1875-375TC	-	1625-2562-375TC
TC12002	312-750-250TC	TC12047	1125-2000-375TC	TC12113	1625-2875-375TC
TC12003	312-875-250TC	TC12056	1250-1687-250TC	TC12114	1625-3000-375TC
TC12004	375-750-250TC	TC12057	1250-1750-250TC	TC12117	1687-2500-375TC
TC12005	375-875-250TC	TC12058	1250-1875-375TC	TC12118	1687-2750-375TC
TC12006	437-1000-250TC	TC12060	1250-2000-375TC	TC12119	1687-3000-375TC
TC12007	500-875-250TC	TC12063	1250-2187-375TC	TC12120	1750-2250-375TC
TC12008	500-1000-250TC	TC12064	1250-2250-375TC	TC12121	1750-2312-250TC
TC12009	500-1125-250TC	TC12067	1250-2750-375TC	TC12122	1750-2375-375TC
TC12010	562-1000-250TC	TC12069	1312-2125-375TC	TC12123	1750-2437-375TC
TC12011	562-1125-250TC	TC12070	1312-2250-375TC	TC12124	1750-2500-375TC
TC12012	625-1000-250TC	TC12071	1312-2375-375TC	TC12125	1750-2625-375TC
TC12013	625-1125-250TC	TC12072	1312-2500-375TC	TC12127	1750-2750-375TC
TC12014	625-1250-250TC	TC12073	1375-1875-250TC	TC12128	1750-2875-375TC
TC12016	625-1500-375TC	TC12074	1375-2000-375TC	TC12129	1750-3000-375TC
TC12017	687-1250-250TC	TC12075	1375-2062-250TC	TC12130	1750-3125-375TC
TC12018	687-1375-250TC	TC12076	1375-2125-375TC	TC12131	1750-3375-375TC
TC12019	750-1125-250TC	TC12077	1375-2250-375TC	TC12132	1750-3500-500TC
TC12020	750-1250-250TC	TC12079	1375-2375-375TC	TC12133	1750-3625-500TC
TC12021	750-1375-250TC	TC12080	1375-2437-375TC	TC12134	1812-2500-375TC
TC12022	750-1500-375TC	TC12081	1375-2500-375TC	TC12135	1812-2625-375TC
TC12023	750-1625-375TC	TC12082	1375-2750-375TC	TC12136	1812-2750-375TC
TC12024	750-1750-375TC	TC12083	1375-3000-375TC	TC12137	1812-2875-375TC
TC12025	812-1375-250TC	TC12085	1437-2250-375TC	TC12138	1812-3000-375TC
TC12026	875-1250-250TC	TC12086	1437-2375-375TC	TC12139	1875-2500-375TC
TC12027	875-1375-250TC	TC12087	1437-2500-375TC	TC12140	1875-2625-375TC
TC12028	875-1500-375TC	TC12090	1500-2062-250TC	TC12141	1875-2750-375TC
TC12029	875-1625-375TC	TC12091	1500-2125-375TC	TC12142	1875-2875-375TC
TC12030	937-1750-375TC	TC12092	1500-2250-375TC	TC12143	1875-3000-375TC
TC12031	1000-1437-250TC	TC12093	1500-2375-375TC	TC12144	1875-3125-375TC
TC12032	1000-1500-375TC	TC12094	1500-2437-375TC	TC12146	1938-2625-375TC
TC12032	1000-1500-250TC	TC12097	1500-2750-375TC	TC12147	1938-2750-375TC
-	1000-1625-375TC	TC12099	1500-3000-375TC	TC12148	1938-3000-375TC
TC12034	1000-1750-375TC	TC12101	1562-2250-375TC	TC12149	2000-2500-250TC
TC12035	1000-1875-250TC	TC12102	1562-2375-375TC	TC12150	2000-2625-375TC
TC12036	1000-2000-375TC	TC12104	1562-2625-375TC	TC12151	2000-2687-375TC
TC12039	1000-2250-375TC	TC12105	1562-2750-375TC	TC12152	2000-2750-375TC
TC12040	1062-1500-250TC	TC12106	1562-3000-375TC	TC12153	2000-2875-375TC
TC12041	1062-1750-375TC	TC12108	1625-2375-375TC	TC12154	2000-3000-375TC
TC12042	1062-1875-375TC	TC12109	1625-2437-375TC	TC12155	2000-3062-375TC
TC12043	1125-1500-250TC	TC12110	1625-2500-375TC	TC12160	2000-3625-500TC
TC12045	1125-1750-375TC				

Oil Seals - TC Cross Reference

TC12161	2000-3750-500TC	TC12239	2875-4500-500TC	TC12308	4250-5250-500TC
TC12163	2062-3000-375TC	TC12241	3000-3750-375TC	TC12309	4250-5500-500TC
TC12164	2125-2750-375TC	TC12242	3000-3875-375TC	TC12311	4250-5750-500TC
TC12165	2125-2875-375TC	TC12247	3000-4500-500TC	TC12314	4375-5250-500TC
TC12166	2125-3000-375TC	TC12249	3000-5000-500TC	TC12315	4375-5375-500TC
TC12168	2125-3125-375TC	TC12250	3125-4000-500TC	TC12316	4375-5750-500TC
TC12169	2125-3250-375TC	TC12254	3187-4250-500TC	TC12317	4375-6000-500TC
TC12173	2187-2875-375TC	TC12255	3187-4500-500TC	TC12319	4500-5250-500TC
TC12174	2187-3000-375TC	TC12256	3250-4000-500TC	TC12321	4500-5500-500TC
TC12175	2187-3250-375TC	TC12257	3250-4250-500TC	TC12323	4500-6000-500TC
TC12177	2250-2750-375TC	TC12258	3250-4500-500TC	TC12326	4625-5750-500TC
TC12178	2250-2875-375TC	TC12262	3312-4500-500TC	TC12328	4750-5750-500TC
TC12179	2250-3000-375TC	TC12263	3375-4250-500TC	TC12334	5000-6000-500TC
TC12181	2250-3125-375TC	TC12266	3375-4750-500TC	TC12335	5000-6250-500TC
TC12182	2250-3187-375TC	TC12267	3375-5000-500TC	TC12336	5000-6500-500TC
TC12185	2250-3500-500TC	TC12268	3437-4500-500TC	TC12337	5250-6250-500SC
TC12186	2250-3625-500TC	TC12271	3500-4375-500TC	TC12340	5500-6500-500TC
TC12189	2313-3187-375TC	TC12272	3500-4500-500TC	TC12341	5625-7000-500TC
TC12190	2313-3375-375TC	TC12273	3500-4625-500TC	TC12342	5750-6750-500TC
TC12192	2375-3000-375TC	TC12274	3500-4750-500TC	TC12344	5875-6875-500TC
TC12193	2375-3125-375TC	TC12275	3500-5000-500TC	TC12345	6000-7000-500TC
TC12195	2375-3375-375TC	TC12276	3500-5250-500TC	TC12346	6000-7500-500TC
TC12196	2375-3500-500TC	TC12280	3625-4625-500TC	TC12348	6250-7250-500TC
TC12200	2437-3250-375TC	TC12281	3625-4750-500TC	TC12349	6500-7500-500TC
TC12201	2437-3625-500TC	TC12282	3625-5000-500TC	TC12350	6750-7750-500TC
TC12202	2500-3000-375TC	TC12285	3687-5625-500TC	TC12351	7000-8000-500TC
TC12203	2500-3187-375TC	TC12287	3750-4750-500TC	TC12353	7250-8750-562TC
TC12204	2500-3250-375TC	TC12288	3750-5000-500TC	TC12357	8500-10000-562TC
TC12206	2500-3500-375TC	TC12289	3750-5625-500TC	TC12361	5 x 18 x 7TC
TC12209	2500-3875-500TC	TC12291	3875-4875-500TC	TC12363	6 x 16 x 7TC
TC12210	2500-4000-500TC	TC12294	3875-5250-500TC	TC12364	6 x 22 x 7TC
TC12214	2562-3500-500TC	TC12295	3875-5375-500TC	TC12366	7 x 22 x 7TC
TC12215	2562-3750-500TC	TC12296	3875-5687-500TC	TC12367	8 x 16 x 7TC
TC12217	2625-3375-375TC	TC12297	3937-5000-500TC	TC12368	8 x 18 x 7TC
TC12222	2625-4000-500TC	TC12298	4000-4750-500TC	TC12369	8 x 22 x 7TC
TC12225	2750-3500-375TC	TC12299	4000-5000-500TC	TC12370	8 x 24 x 7TC
TC12227	2750-3750-375TC	TC12300	4000-5125-500TC	TC12371	9 x 22 x 7TC
TC12229	2750-4000-500TC	TC12301	4000-5250-500TC	TC12372	9 x 24 x 7TC
TC12331	2750-4250-500SC	TC12302	4000-5375-500TC	TC12374	9 x 26 x 7TC
TC12232	2750-4500-500TC	TC12303	4000-5500-500TC	TC12375	9 x 28 x 8TC
TC12233	2812-3625-375TC	TC12304	4000-5750-500TC		
TC12235	2875-3625-375TC	TC12305	4125-5000-500TC		
TC12238	2875-4000-500TC	TC12307	4250-5000-500TC		

Oil Seals - TC Cross Reference

TC12378	10 x 19 x 7TC	TC12430	19 x 32 x 7TC	TC12491	30 x 45 x 7TC
TC12379	10 x 20 x 7TC	TC12434	20 x 30 x 7TC	TC12492	30 x 47 x 7TC
TC12380	10 x 22 x 7TC	TC12435	20 x 32 x 7TC	TC12493	30 x 48 x 7TC
TC12381	10 x 24 x 7TC	TC12436	20 x 35 x 7TC	TC12494	30 x 50 x 8TC
TC12382	10 x 25 x 7TC	TC12437	20 x 36 x 7TC	TC12495	30 x 52 x 7TC
TC12383	10 x 26 x 7TC	TC12438	20 x 37 x 7TC	TC12497	30 x 56 x 10TC
TC12384	10 x 28 x 7TC	TC12439	20 x 38 x 7TC	TC12498	30 x 58 x 10TC
TC12385	11 x 22 x 7TC	TC12440	20 x 40 x 7TC	TC12499	30 x 60 x 8TC
TC12387	12 x 22 x 7TC	TC12441	20 x 42 x 7TC	TC12501	30 x 72 x 8TC
TC12388	12 x 24 x 7TC	TC12442	20 x 45 x 7TC	TC12504	32 x 47 x 7TC
TC12389	12 x 25 x 7TC	TC12443	20 x 47 x 7TC	TC12507	32 x 52 x 7TC
TC12390	12 x 26 x 7TC	TC12446	22 x 32 x 7TC	TC12510	32 x 62 x 8TC
TC12391	12 x 28 x 7TC	TC12447	22 x 35 x 7TC	TC12511	33 x 45 x 7TC
TC12392	12 x 30 x 7TC	TC12448	22 x 38 x 7TC	TC12515	34 x 52 x 8TC
TC12393	12 x 32 x 7TC	TC12451	22 x 43 x 8TC	TC12516	34 x 62 x 10TC
TC12395	14 x 24 x 7TC	TC12452	22 x 45 x 7TC	TC12518	35 x 45 x 7TC
TC12396	14 x 28 x 7TC	TC12453	22 x 47 x 7TC	TC12519	35 x 47 x 7TC
TC12397	14 x 30 x 7TC	TC12454	24 x 34 x 7TC	TC12520	35 x 48 x 8TC
TC12398	14 x 35 x 7TC	TC12455	24 x 35 x 7TC	TC12525	35 x 58 x 10TC
TC12400	15 x 24 x 7TC	TC12456	24 x 37 x 7TC	TC12532	36 x 47 x 7TC
TC12401	15 x 25 x 7TC	TC12458	24 x 40 x 7TC	TC12533	36 x 50 x 7TC
TC12402	15 x 26 x 7TC	TC12459	24 x 42 x 7TC	TC12535	36 x 54 x 8TC
TC12403	15 x 28 x 7TC	TC12460	24 x 47 x 7TC	TC12538	37 x 52 x 7TC
TC12404	15 x 30 x 7TC	TC12463	25 x 35 x 7TC	TC12539	38 x 50 x 7TC
TC12405	15 x 32 x 7TC	TC12464	25 x 36 x 7TC	TC12541	38 x 54 x 8TC
TC12406	15 x 33 x 7TC	TC12465	25 x 37 x 7TC	TC12543	38 x 56 x 10TC
TC12407	15 x 35 x 7TC	TC12466	25 x 38 x 7TC	TC12545	38 x 60 x 8TC
TC12411	16 x 28 x 7TC	TC12467	25 x 39 x 7TC	TC12549	40 x 50 x 8TC
TC12412	16 x 30 x 7TC	TC12468	25 x 40 x 7TC	TC12551	40 x 54 x 7TC
TC12413	16 x 32 x 7TC	TC12472	25 x 47 x 7TC	TC12552	40 x 55 x 8TC
TC12414	16 x 35 x 7TC	TC12473	25 x 52 x 7TC	TC12553	40 x 56 x 8TC
TC12417	17 x 28 x 7TC	TC12475	26 x 37 x 7TC	TC12557	40 x 65 x 8TC
TC12418	17 x 30 x 7TC	TC12477	26 x 47 x 7TC	TC12559	40 x 70 x 8TC
TC12419	17 x 32 x 7TC	TC12478	27 x 37 x 7TC	TC12561	40 x 75 x 8TC
TC12420	17 x 35 x 7TC	TC12481	28 x 38 x 7TC	TC12562	40 x 80 x 10TC
TC12421	17 x 37 x 7TC	TC12483	28 x 43 x 7TC	TC12566	42 x 60 x 8TC
TC12425	18 x 28 x 7TC	TC12484	28 x 47 x 7TC	TC12567	42 x 62 x 8TC
TC12426	18 x 30 x 7TC	TC12487	30 x 40 x 7TC	TC12569	42 x 72 x 8TC
TC12427	18 x 32 x 7TC	TC12488	30 x 42 x 7TC	TC12570	44 x 60 x 7TC
TC12428	18 x 35 x 7TC	TC12489	30 x 43 x 8TC	TC12571	44 x 62 x 8TC
TC12429	18 x 40 x 7TC	TC12490	30 x 44 x 9TC	TC12572	44 x 65 x 8TC

Oil Seals - TC Cross Reference

TC12574	45 x 55 x 7TC	TC12637	62 x 100 x 10TC	TC12691	100 x 130 x 12TC
TC12575	45 x 58 x 7TC	TC12638	63 x 85 x 10TC	TC12692	100 x 135 x 12TC
TC12576	45 x 60 x 8TC	TC12639	63 x 90 x 10TC	TC12693	100 x 140 x 13TC
TC12577	45 x 62 x 8TC	TC12640	64 x 80 x 8TC	TC12694	100 x 150 x 13TC
TC12578	45 x 65 x 8TC	TC12642	65 x 85 x 10TC	TC12695	105 x 125 x 13TC
TC12580	45 x 72 x 8TC	TC12643	65 x 90 x 10TC	TC12696	105 x 130 x 12TC
TC12582	45 x 80 x 10TC	TC12644	65 x 95 x 10TC	TC12697	105 x 140 x 12TC
TC12583	45 x 85 x 10TC	TC12645	65 x 100 x 10TC	TC12698	110 x 130 x 12TC
TC12585	48 x 60 x 8TC	TC12646	68 x 85 x 10TC	TC12700	110 x 140 x 12TC
TC12586	48 x 62 x 8TC	TC12647	68 x 88 x 9TC	TC12702	110 x 160 x 13TC
TC12589	48 x 72 x 8TC	TC12649	68 x 100 x 10TC	TC12704	114 x 135 x 13TC
TC12590	48 x 74 x 10TC	TC12651	70 x 90 x 10TC	TC12705	115 x 140 x 12TC
TC12591	48 x 75 x 8TC	TC12652	70 x 95 x 10TC	TC12708	120 x 140 x 13TC
TC12592	48 x 80 x 8TC	TC12653	70 x 100 x 10TC	TC12710	120 x 150 x 12TC
TC12594	50 x 62 x 8TC	TC12654	70 x 110 x 10TC	TC12712	120 x 160 x 12TC
TC12595	50 x 65 x 8TC	TC12655	72 x 95 x 10TC	TC12714	125 x 143 x 13TC
TC12596	50 x 68 x 8TC	TC12656	72 x 100 x 10TC	TC12715	125 x 150 x 12TC
TC12597	50 x 70 x 8TC	TC12657	72 x 105 x 13TC	TC12717	125 x 160 x 12TC
TC12598	50 x 72 x 8TC	TC12659	75 x 95 x 10TC	TC12726	140 x 175 x 15TC
TC12599	50 x 75 x 10TC	TC12660	75 x 100 x 10TC	TC12730	145 x 175 x 15TC
TC12601	50 x 82 x 8TC	TC12662	75 x 110 x 10TC	TC12733	150 x 180 x 12TC
TC12603	50 x 90 x 10TC	TC12663	75 x 115 x 12TC	TC12734	150 x 190 x 15TC
TC12604	50 x 110 x 10TC	TC12664	78 x 100 x 10TC	TC12736	155 x 190 x 15TC
TC12605	52 x 68 x 8TC	TC12665	80 x 100 x 10TC	TC12741	165 x 200 x 15TC
TC12606	52 x 70 x 8TC	TC12666	80 x 105 x 10TC	TC12742	170 x 190 x 13TC
TC12608	53 x 68 x 10TC	TC12667	80 x 110 x 10TC	TC12743	170 x 200 x 15TC
TC12609	54 x 68 x 10TC	TC12668	80 x 115 x 13TC	TC12744	175 x 200 x 15TC
TC12614	55 x 75 x 10TC	TC12670	85 x 100 x 10TC	TC12745	175 x 210 x 15TC
TC12618	55 x 90 x 10TC	TC12671	85 x 105 x 10TC	TC12746	180 x 200 x 15TC
TC12619	55 x 100 x 10TC	TC12673	85 x 115 x 13TC	TC12747	180 x 210 x 15TC
TC12620	56 x 70 x 8TC	TC12674	85 x 120 x 12TC	TC12751	190 x 220 x 15TC
TC12621	56 x 72 x 8TC	TC12676	85 x 140 x 12TC	TC12752	200 x 230 x 15TC
TC12622	56 x 80 x 8TC	TC12679	90 x 118 x 12TC	TC12753	200 x 240 x 15TC
TC12623	58 x 72 x 8TC	TC12680	90 x 120 x 12TC	TC12754	210 x 240 x 15TC
TC12624	58 x 80 x 8TC	TC12683	95 x 110 x 12TC	TC12755	210 x 250 x 15TC
TC12626	60 x 75 x 8TC	TC12685	95 x 120 x 12TC	TC12756	215 x 240 x 12TC
TC12630	60 x 85 x 8TC	TC12686	95 x 125 x 12TC	TC12757	220 x 250 x 15TC
TC12632	60 x 95 x 10TC	TC12688	100 x 118 x 12TC	TC12758	230 x 260 x 15TC
TC12633	60 x 110 x 10TC	TC12689	100 x 120 x 12TC	TC12760	230 x 280 x 15TC
TC12636	62 x 90 x 10TC	TC12690	100 x 125 x 12TC	TC12761	240 x 270 x 15TC
				TC12762	240 x 280 x 15TC

Oil Seals - TC Cross Reference

TC12763	250 x 280 x 15TC	TC12834	27 x 47 x 8TC	TC12863	42 x 75 x 8TC
TC12765	260 x 300 x 18TC	TC12835	28 x 42 x 8TC	TC12873	47 x 62 x 8TC
TC12766	270 x 300 x 15TC	TC12836	28 x 45 x 8TC	TC12875	48 x 70 x 8TC
TC12768	875-1875-375TC	TC12838	28 x 50 x 8TC	TC12876	48 x 82 x 8TC
TC12769	875-2000-375TC	TC12840	30 x 65 x 8TC	TC12877	48 x 85 x 8TC
TC12796	3250-4375-500TC	TC12841	30 x 70 x 8TC	TC12885	55 x 95 x 10TC
TC12812	4937-6000-500TC	TC12842	32 x 46 x 8TC	TC12888	56 x 85 x 8TC
TC12818	12 x 27 x 7TC	TC12843	32 x 54 x 8TC	TC12893	62 x 95 x 10TC
TC12819	17 x 45 x 7TC	TC12844	32 x 58 x 8TC	TC12896	65 x 88 x 8TC
TC12820	18 x 36 x 7TC	TC12845	34 x 48 x 8TC	TC12897	65 x 105 x 10TC
TC12821	18 x 38 x 7TC	TC12850	35 x 54 x 8TC	TC12899	70 x 105 x 10TC
TC12822	19 x 35 x 7TC	TC12852	35 x 75 x 8TC	TC12900	72 x 88 x 8TC
TC12823	19 x 36 x 7TC	TC12856	38 x 80 x 8TC	TC12904	80 x 140 x 12TC
TC12824	19 x 42 x 7TC	TC12857	40 x 72 x 8TC	TC12906	90 x 135 x 12TC
TC12825	19 x 45 x 7TC	TC12858	40 x 85 x 8TC	TC12907	90 x 140 x 12TC
TC12826	19 x 47 x 7TC	TC12859	40 x 90 x 8TC	TC12908	110 x 145 x 12TC
TC12829	24 x 50 x 8TC	TC12860	42 x 58 x 8TC	TC13212	4250-6000-500TC
TC12831	25 x 50 x 8TC	TC12862	42 x 70 x 8TC		

Viton Oil Seals - Metric

Part Number, TC Number & Dimensions (mm)		Part Number, TC Number & Dimensions (mm)		Part Number, TC Number & Dimensions (mm)	
8 x 22 x 7TCV	TC12369VI (8 x 22 x 7)	23 x 40 x 6TCV	(23 x 40 x 6)	35 x 55 x 10TCV	(35 x 55 x 10)
10 x 18 x 6TCV	TC12377VI (10 x 18 x 6)	24 x 40 x 7TCV	TC12458VI (24 x 40 x 7)	35 x 62 x 7TCV	TC12527VI (35 x 62 x 7)
10 x 19 x 7TCV	TC12378VI (10 x 19 x 7)	24 x 42 x 8TCV	TC12459VI (24 x 42 x 8)	35 x 72 x 8TCV	(35 x 72 x 8)
10 x 20 x 7TCV	TC12379VI (10 x 20 x 7)	25 x 35 x 7TCV	TC12463VI (25 x 35 x 7)	36 x 50 x 7TCV	TC12533VI (36 x 50 x 7)
10 x 22 x 7TCV	TC12380VI (10 x 22 x 7)	25 x 37 x 7TCV	TC12465VI (25 x 37 x 7)	38 x 50 x 7TCV	TC12539VI (38 x 50 x 7)
10 x 25 x 7TCV	TC12382VI (10 x 25 x 7)	25 x 38 x 7TCV	TC12466VI (25 x 38 x 7)	38 x 52 x 7TCV	TC12540VI (38 x 52 x 7)
10 x 26 x 7TCV	TC12383VI (10 x 26 x 7)	25 x 40 x 7TCV	TC12468VI (25 x 40 x 7)	38 x 55 x 7TCV	TC12542VI (38 x 55 x 7)
12 x 19 x 5TCV	(12 x 19 x 5)	25 x 42 x 7TCV	TC12469VI (25 x 42 x 7)	38 x 62 x 7TCV	TC12546VI (38 x 62 x 7)
12 x 20 x 5TCV	(12 x 20 x 5)	25 x 43 x 7TCV	(25 x 43 x 7)	40 x 50 x 7TCV	(40 x 50 x 7)
12 x 22 x 7TCV	TC12387VI (12 x 22 x 7)	25 x 47 x 7TCV	TC12472VI (25 x 47 x 7)	40 x 52 x 7TCV	TC12550VI (40 x 52 x 7)
12 x 24 x 7TCV	TC12388VI (12 x 24 x 7)	25 x 52 x 7TCV	TC12473VI (25 x 52 x 7)	40 x 55 x 7TCV	(40 x 55 x 7)
12 x 30 x 7TCV	TC12392VI (12 x 30 x 7)	25 x 62 x 7TCV	TC12474VI (25 x 62 x 7)	40 x 58 x 10TCV	TC12554VI (40 x 58 x 10)
14 x 24 x 5TCV	(14 x 24 x 5)	27 x 40 x 8TCV	(27 x 40 x 8)	40 x 60 x 10TCV	(40 x 60 x 10)
14 x 28 x 7TCV	TC12396VI (14 x 28 x 7)	27 x 47 x 8TCV	TC12834VI (27 x 47 x 8)	40 x 62 x 7TCV	TC12556VI (40 x 62 x 7)
15 x 24 x 7TCV	TC12400VI (15 x 24 x 7)	28 x 38 x 7TCV	TC12481VI (28 x 38 x 7)	40 x 65 x 10TCV	(40 x 65 x 10)
15 x 25 x 7TCV	TC12401VI (15 x 25 x 7)	28 x 40 x 7TCV	TC12482VI (28 x 40 x 7)	40 x 68 x 10TCV	(40 x 68 x 10)
15 x 30 x 7TCV	TC12404VI (15 x 30 x 7)	28 x 40 x 8TCV	(28 x 40 x 8)	40 x 72 x 7TCV	TC12560VI (40 x 72 x 7)
15 x 32 x 7TCV	TC12405VI (15 x 32 x 7)	28 x 52 x 7TCV	TC12485VI (28 x 52 x 7)	40 x 80 x 10TCV	(40 x 80 x 10)
15 x 35 x 7TCV	TC12407VI (15 x 35 x 7)	30 x 40 x 7TCV	TC12487VI (30 x 40 x 7)	40 x 85 x 10TCV	(40 x 85 x 10)
16 x 28 x 7TCV	TC12411VI (16 x 28 x 7)	30 x 42 x 7TCV	TC12488VI (30 x 42 x 7)	40 x 90 x 12TCV	(40 x 90 x 12)
16 x 32 x 7TCV	TC12413VI (16 x 32 x 7)	30 x 45 x 7TCV	TC12491VI (30 x 45 x 7)	42 x 55 x 8 TCV	(42 x 55 x 8)
16 x 35 x 7TCV	TC12414VI (16 x 35 x 7)	30 x 47 x 7TCV	TC12492VI (30 x 47 x 7)	42 x 56 x 7TCV	TC12565VI (42 x 56 x 7)
17 x 28 x 7TCV	TC12417VI (17 x 28 x 7)	30 x 48 x 8TCV	(30 x 48 x 8)	42 x 60 x 7TCV	(42 x 60 x 7)
17 x 30 x 7TCV	TC12418VI (17 x 30 x 7)	30 x 50 x 7TCV	(30 x 50 x 7)	42 x 62 x 8TCV	TC12567VI (42 x 62 x 8)
17 x 32 x 7TCV	TC12419VI (17 x 32 x 7)	30 x 52 x 7TCV	TC12495VI (30 x 52 x 7)	42 x 65 x 8TCV	(42 x 65 x 8)
17 x 35 x 7TCV	TC12420VI (17 x 35 x 7)	30 x 55 x 7TCV	TC12496VI (30 x 55 x 7)	42 x 72 x 8TCV	TC12569VI (42 x 72 x 8)
18 x 30 x 7TCV	TC12426VI (18 x 30 x 7)	30 x 62 x 7TCV	TC12500VI (30 x 62 x 7)	44 x 92 x 10TCV	(44 x 92 x 10)
18 x 32 x 7TCV	TC12427VI (18 x 32 x 7)	30 x 72 x 8TCV	TC12501VI (30 x 72 x 8)	45 x 58 x 7TCV	TC12575VI (45 x 58 x 7)
18 x 35 x 7TCV	TC12428VI (18 x 35 x 7)	32 x 40 x 7TCV	(32 x 40 x 7)	45 x 60 x 8TCV	TC12576VI (45 x 60 x 8)
19 x 30 x 7TCV	(19 x 30 x 7)	32 x 42 x 7TCV	TC12502VI (32 x 42 x 7)	45 x 62 x 7TCV	(45 x 62 x 7)
20 x 30 x 7TCV	TC12434VI (20 x 30 x 7)	32 x 45 x 7TCV	TC12503VI (32 x 45 x 7)	45 x 65 x 10TCV	(45 x 65 x 10)
20 x 32 x 7TCV	TC12435VI (20 x 32 x 7)	32 x 47 x 7TCV	TC12504VI (32 x 47 x 7)	45 x 65 x 8TCV	TC12578VI (45 x 65 x 8)
20 x 35 x 7TCV	TC12436VI (20 x 35 x 7)	32 x 48 x 8TCV	(32 x 48 x 8)	45 x 68 x 8TCV	(45 x 68 x 8)
20 x 40 x 7TCV	TC12440VI (20 x 40 x 7)	32 x 52 x 7TCV	TC12507VI (32 x 52 x 7)	45 x 72 x 8TCV	TC12580VI (45 x 72 x 8)
20 x 42 x 7TCV	TC12441VI (20 x 42 x 7)	33 x 45 x 7TCV	TC12511VI (33 x 45 x 7)	45 x 75 x 8TCV	TC12581VI (45 x 75 x 8)
20 x 47 x 7TCV	TC12443VI (20 x 47 x 7)	34 x 52 x 8TCV	TC12515VI (34 x 52 x 8)	45 x 80 x 10TCV	TC12582VI (45 x 80 x 10)
22 x 32 x 7TCV	TC12446VI (22 x 32 x 7)	35 x 45 x 7TCV	TC12518VI (35 x 45 x 7)	45 x 85 x 10TCV	TC12583VI (45 x 85 x 10)
22 x 35 x 7TCV	TC12447VI (22 x 35 x 7)	35 x 47 x 7TCV	TC12519VI (35 x 47 x 7)	46 x 64 x 8TCV	(46 x 64 x 8)
22 x 40 x 7TCV	TC12449VI (22 x 40 x 7)	35 x 50 x 7TCV	TC12521VI (35 x 50 x 7)	47 x 62 x 8TCV	TC12869VI (47 x 62 x 8)
22 x 47 x 7TCV	TC12453VI (22 x 47 x 7)	35 x 52 x 7TCV	TC12522VI (35 x 52 x 7)	48 x 65 x 8TCV	(48 x 65 x 8)

Viton Oil Seals - Metric

Part Number, TC Number & Dimensions (mm)		Part Number, TC Number & Dimensions (mm)		Part Number, TC Number & Dimensions (mm)	
48 x 72 x 8TCV	TC12589VI (48 x 72 x 8)	64 x 90 x 13TCV	(64 x 90 x 13)	90 x 115 x 13TCV	(90 x 115 x 13)
48 x 80 x 10TCV	(48 x 80 x 10)	65 x 100 x 10TCV	TC12645VI (65 x 100 x 10)	90 x 120 x 12TCV	TC12680VI (90 x 120 x 12)
49 x 92 x 10TCV	(49 x 92 x 10)	65 x 110 x 10TCV	(65 x 110 x 10)	90 x 130 x 12TCV	TC12682VI (90 x 130 x 12)
50 x 62 x 8TCV	TC12594VI (50 x 62 x 8)	65 x 80 x 8TCV	TC12641VI (65 x 80 x 8)	95 x 115 x 13TCV	TC12684VI (95 x 115 x 13)
50 x 65 x 8TCV	TC12595VI (50 x 65 x 8)	65 x 85 x 10TCV	TC12642VI (65 x 85 x 10)	95 x 120 x 12TCV	TC12685VI (95 x 120 x 12)
50 x 68 x 8TCV	TC12596VI (50 x 68 x 8)	65 x 85 x 8TCV	(65 x 85 x 8)	95 x 125 x 12TCV	TC12686VI (95 x 125 x 12)
50 x 70 x 8TCV	TC12597VI (50 x 70 x 8)	65 x 90 x 10TCV	TC12643VI (65 x 90 x 10)	100 x 115 x 9TCV	(100 x 115 x 9)
50 x 72 x 8TCV	TC12598VI (50 x 72 x 8)	65 x 90 x 7TCV	(65 x 90 x 7)	100 x 120 x 10TCV	(100 x 120 x 10)
50 x 75 x 10TCV	TC12599VI (50 x 75 x 10)	68 x 90 x 8TCV	TC12648VI (68 x 90 x 8)	100 x 125 x 12TCV	TC12690VI (100 x 125 x 12)
50 x 80 x 8TCV	TC12600VI (50 x 80 x 8)	68 x 95 x 13TCV	(68 x 95 x 13)	100 x 130 x 12TCV	TC12691VI (100 x 130 x 12)
50 x 85 x 8TCV	TC12602VI (50 x 85 x 8)	70 x 100 x 10TCV	TC12653VI (70 x 100 x 10)	100 x 140 x 12TCV	(100 x 140 x 12)
50 x 90 x 10TCV	TC12603VI (50 x 90 x 10)	70 x 110 x 10TCV	TC12654VI (70 x 110 x 10)	100 x 150 x 13TCV	TC12694VI (100 x 150 x 13)
52 x 68 x 8TCV	TC12605VI (52 x 68 x 8)	70 x 125 x 12TCV	(70 x 125 x 12)	105 x 120 x 13TCV	(105 x 120 x 13)
52 x 72 x 8TCV	TC12607VI (52 x 72 x 8)	70 x 85 x 8TCV	TC12650VI (70 x 85 x 8)	105 x 130 x 12TCV	TC12696VI (105 x 130 x 12)
52 x 80 x 10TCV	(52 x 80 x 10)	70 x 90 x 10TCV	TC12651VI (70 x 90 x 10)	110 x 130 x 12TCV	TC12698VI (110 x 130 x 12)
55 x 100 x 10TCV	TC12619VI (55 x 100 x 10)	70 x 92 x 10TCV	(70 x 92 x 10)	110 x 135 x 13TCV	TC12699VI (110 x 135 x 13)
55 x 120 x 12TCV	(55 x 120 x 12)	70 x 95 x 10TCV	TC12652VI (70 x 95 x 10)	110 x 140 x 12TCV	TC12700VI (110 x 140 x 12)
55 x 68 x 8TCV	TC12611VI (55 x 68 x 8)	72 x 100 x 10TCV	TC12656VI (72 x 100 x 10)	110 x 150 x 15TCV	(110 x 150 x 15)
55 x 70 x 10TCV	(55 x 70 x 10)	72 x 95 x 10TCV	TC12655VI (72 x 95 x 10)	115 x 140 x 12TCV	TC12705VI (115 x 140 x 12)
55 x 70 x 8TCV	TC12612VI (55 x 70 x 8)	75 x 100 x 10TCV	TC12660VI (75 x 100 x 10)	120 x 140 x 13TCV	TC12708VI (120 x 140 x 13)
55 x 72 x 8TCV	TC12613VI (55 x 72 x 8)	75 x 110 x 10TCV	TC12662VI (75 x 110 x 10)	120 x 145 x 12TCV	TC12709VI (120 x 145 x 12)
55 x 75 x 8TCV	(55 x 75 x 8)	75 x 130 x 13TCV	(75 x 130 x 13)	120 x 150 x 12TCV	TC12710VI (120 x 150 x 12)
55 x 78 x 8TCV	TC12615VI (55 x 78 x 8)	75 x 90 x 8TCV	TC12658VI (75 x 90 x 8)	125 x 145 x 13TCV	(125 x 145 x 13)
55 x 80 x 8TCV	TC12616VI (55 x 80 x 8)	75 x 95 x 10TCV	TC12659VI (75 x 95 x 10)	125 x 150 x 12TCV	TC12715VI (125 x 150 x 12)
55 x 85 x 10TCV	TC12617VI (55 x 85 x 10)	78 x 100 x 10TCV	TC12664VI (78 x 100 x 10)	130 x 150 x 10TCV	TC12718VI (130 x 150 x 10)
55 x 90 x 10TCV	TC12618VI (55 x 90 x 10)	80 x 100 x 10TCV	TC12665VI (80 x 100 x 10)		
58 x 72 x 8TCV	TC12623VI (58 x 72 x 8)	80 x 105 x 10TCV	TC12666VI (80 x 105 x 10)		
58 x 80 x 8TCV	TC12624VI (58 x 80 x 8)	80 x 110 x 10TCV	TC12667VI (80 x 110 x 10)		
60 x 100 x 10TCV	(60 x 100 x 10)	80 x 115 x 10TCV	(80 x 115 x 10)		
60 x 110 x 10TCV	TC12633VI (60 x 110 x 10)	80 x 120 x 13TCV	(80 x 120 x 13)		
60 x 75 x 8TCV	TC12626VI (60 x 75 x 8)	80 x 125 x 12TCV	(80 x 125 x 12)		
60 x 78 x 10TCV	(60 x 78 x 10)	85 x 100 x 10TCV	TC12670VI (85 x 100 x 10)		
60 x 80 x 8TCV	TC12628VI (60 x 80 x 8)	85 x 105 x 12TCV	(85 x 105 x 12)		
60 x 85 x 8TCV	TC12630VI (60 x 85 x 8)	85 x 110 x 12TCV	TC12672VI (85 x 110 x 12)		
60 x 90 x 8TCV	TC12631VI (60 x 90 x 8)	85 x 115 x 13TCV	TC12673VI (85 x 115 x 13)		
60 x 95 x 10TCV	TC12632VI (60 x 95 x 10)	85 x 120 x 12TCV	TC12674VI (85 x 120 x 12)		
62 x 85 x 10TCV	TC12635VI (62 x 85 x 10)	90 x 100 x 10TCV	(90 x 100 x 10)		
62 x 90 x 10TCV	TC12636VI (62 x 90 x 10)	90 x 110 x 10TCV	TC12677VI (90 x 110 x 10)		
63 x 85 x 10TCV	TC12638VI (63 x 85 x 10)	90 x 110 x 12TCV	(90 x 110 x 12)		
64 x 80 x 8TCV	TC12640VI (64 x 80 x 8)	90 x 115 x 12TCV	(90 x 115 x 12)		

Viton Oil Seals - Imperial

Legend: 1000 = 1"

Part Number, TC Number & Dimensions (Inches)	
500-1125-250TCV	TC12009VI (1/2 x 1-1/8 x 1/4)
625-1125-250TCV	TC12013VI (5/8 x 1-1/8 x 1/4)
750-1250-250TCV	TC12020VI (3/4 x 1-1/4 x 1/4)
750-1375-250TCV	TC12021VI (3/4 x 1-3/8 x 1/4)
750-1500-250TCV	(3/4 x 1-1/2 x 1/4)
781-1750-313TCV	(25/32 x 1-3/4 x 5/16)
1000-1437-250TCV	TC12031VI (1 x 1-7/16 x 1/4)
1000-1500-250TCV	TC12032VI (1 x 1-1/2 x 1/4)
1000-1750-375TCV	TC12034VI (1 x 1-3/4 x 3/8)
1000-2250-375TCV	TC12039VI (1 x 2-1/4 x 3/8)
1250-1750-250TCV	TC12057VI (1-1/4 x 1-3/4 x 1/4)
1250-1875-250TCV	(1-1/4 x 1-7/8 x 1/4)
1250-2000-375TCV	TC12060VI (1-1/4 x 2 x 3/8)
1250-2250-375TCV	TC12064VI (1-1/4 x 2-1/4 x 3/8)
1500-2250-375TCV	TC12092VI (1-1/2 x 2-1/4 x 3/8)
1500-2750-500TCV	(1-1/2 x 2-3/4 x 1/2)
1750-2250-312TCV	(1-3/4 x 2-1/4 x 5/16)
1750-2500-375TCV	TC12124VI (1-3/4 x 2-1/2 x 3/8)
1750-2750-375TCV	TC12127VI (1-3/4 x 2-3/4 x 3/8)
2000-3000-375TCV	TC12154VI (2 x 3 x 3/8)
2500-3250-375TCV	TC12204VI (2-1/2 x 3-1/4 x 3/8)
2625-3500-500TCV	TC12218VI (2-5/8 x 3-1/2 x 1/2)
3000-4000-375TCV	TC12243VI (3 x 4 x 3/8)
3000-4250-437TCV	(3 x 4-1/4 x 7/16)
3500-4500-375TCV	TC12272VI (3-1/2 x 4-1/2 x 3/8)



Automotive Oil Seals - Metric

Part No.	ID (mm)	OD (mm)	Thickness (mm)	Alternate Part Numbers		Car References
PR4750	42.85	59.13	10.2	C610	C4750	Ford Road C4750
PR6518	36.5	59.13	6.35	C6518	-	Holden Road C6518
PR6521	38.1	59.13	9.52	C609A	-	Holden Road
38-107	38	74	11	-	-	Toyota Pinion
62-017	62	85	8/10	-	-	Toyota Hub
65-047	65	88	9/19	-	-	Nisan Patrol Hub
C610	42.84	59.13	9.52	PR4750	-	Ford Road - Metal Casing
C609A	38.1	59.13	10.31	PR6521	-	Holden Road - Metal Casing
64190	50	85	10	-	-	-
64607	60.375	90	13	-	-	-
82130	48	85	13	-	-	-
82140	60	90	18	-	-	-

Automotive Oil Seals - Imperial

Part No.	ID (mm)	OD (mm)	Thickness (mm)	Alternate Part Numbers		Car References
PR6641	1.450	2.343	0.539	-	-	Holden Marine
PR6692	1.687	2.328	0.590	-	-	Ford Marine
PR6693	1.473	2.328	0.590	-	-	Ford & Holden Marine
30340	1.750	2.723	0.375	-	-	-
30360	1.875	2.723	0.437	-	-	-
30400	2.000	2.723	0.375	-	-	-
31820	1.875	3.111	0.375	-	-	-
33940	1.937	3.375	0.500	-	-	-
33960	2.000	3.375	0.500	-	-	-
33970	2.062	3.375	0.500	-	-	-
34040	2.250	3.375	0.500	-	-	-
82100	1.468	2.328	0.400	-	-	-
82120	1.750	2.328	0.400	-	-	-

Trailer & Caravan Oil Seals

Part No.	Description	Dimensions
30340	Road Seal	1-3/4 x 2.723 x 3/8
30360	Road Seal	1-7/8 x 2.723 x 7/16
30400	Road Seal	2 x 2.723 x 3/8
31820	Road Seal	1-7/8 x 3 x 3/8
33940	Road Seal	1-15/16 x 3-3/8 x 1/2
33960	Road Seal	2 x 3-3/8 x 1/2
33970	Road Seal	2-1/16 x 3-3/8 x 1/2
34040	Road Seal	2-1/4 x 3-3/8 x 1/2
64190	Road Seal	50 x 85 x 10
64607	Road Seal	2-3/8 x 90 x 13
82100	Marine Seal	1.468 x 2.328 x 0.400
82120	Marine Seal	1-3/4 x 2.328 x 0.400
82130	Marine Seal	48 x 85 x 13
82140	Marine Seal	60 x 90 x 18

Road Seals - Metal Cased (TB Style)



Marine Seals - 2 Piece (Rubber & Stainless Steel)

Part No.	Description	Dimensions
82100	Marine Seal	1.468 x 2.328 x 0.400
82120	Marine Seal	1-3/4 x 2.328 x 0.400
82130	Marine Seal	48 x 85 x 13
82140	Marine Seal	60 x 90 x 18

BS Series O-Rings (NBR - 70 Duro)

SIZE	Nominal (Reference)			Measurement (Inch)				Measurement (mm)			
	ID	OD	CS	ID	±	CS	±	ID	±	CS	±
BS001	1/32	3/32	1/32	0.029	0.004	0.04	0.003	0.74	0.1	1.02	0.08
BS002	3/64	9/64	3/64	0.042	0.004	0.05	0.003	1.07	0.1	1.27	0.08
BS003	1/16	3/16	1/16	0.056	0.004	0.06	0.003	1.42	0.1	1.52	0.08
BS004	5/64	13/64	1/16	0.07	0.005	0.07	0.003	1.78	0.13	1.78	0.08
BS005	3/32	7/32	1/16	0.101	0.005	0.07	0.003	2.57	0.13	1.78	0.08
BS006	1/8	1/4	1/16	0.114	0.005	0.07	0.003	2.9	0.13	1.78	0.08
BS007	5/32	9/32	1/16	0.145	0.005	0.07	0.003	3.68	0.13	1.78	0.08
BS008	3/16	5/16	1/16	0.176	0.005	0.07	0.003	4.47	0.13	1.78	0.08
BS009	7/32	11/32	1/16	0.208	0.005	0.07	0.003	5.28	0.13	1.78	0.08
BS010	1/4	3/8	1/16	0.239	0.005	0.07	0.003	6.07	0.13	1.78	0.08
BS011	5/16	7/16	1/16	0.301	0.005	0.07	0.003	7.65	0.13	1.78	0.08
BS012	3/8	1/2	1/16	0.364	0.005	0.07	0.003	9.25	0.13	1.78	0.08
BS013	7/16	9/16	1/16	0.426	0.005	0.07	0.003	10.82	0.13	1.78	0.08
BS014	1/2	5/8	1/16	0.489	0.005	0.07	0.003	12.42	0.13	1.78	0.08
BS015	9/16	11/16	1/16	0.551	0.007	0.07	0.003	14	0.18	1.78	0.08
BS016	5/8	3/4	1/16	0.614	0.009	0.07	0.003	15.6	0.23	1.78	0.08
BS017	11/16	13/16	1/16	0.676	0.009	0.07	0.003	17.17	0.23	1.78	0.08
BS018	3/4	7/8	1/16	0.739	0.009	0.07	0.003	18.77	0.23	1.78	0.08
BS019	13/16	15/16	1/16	0.801	0.009	0.07	0.003	20.35	0.23	1.78	0.08
BS020	44050	1	1/16	0.864	0.009	0.07	0.003	21.95	0.23	1.78	0.08
BS021	15/16	1 1/16	1/16	0.926	0.009	0.07	0.003	23.52	0.23	1.78	0.08
BS022	1	1/8	1/16	0.989	0.01	0.07	0.003	25.12	0.25	1.78	0.08
BS023	1.0625	1 3/16	1/16	1.051	0.01	0.07	0.003	26.7	0.25	1.78	0.08
BS024	1.125	1 1/4	1/16	1.114	0.01	0.07	0.003	28.3	0.25	1.78	0.08
BS025	1.1875	1 5/16	1/16	1.176	0.011	0.07	0.003	29.87	0.28	1.78	0.08
BS026	1.25	1 3/8	1/16	1.239	0.011	0.07	0.003	31.47	0.28	1.78	0.08
BS027	1.3125	1 7/16	1/16	1.301	0.011	0.07	0.003	33.05	0.28	1.78	0.08
BS028	1.375	1 1/2	1/16	1.364	0.013	0.07	0.003	34.65	0.33	1.78	0.08
BS029	1.5	1 5/8	1/16	1.489	0.013	0.07	0.003	37.82	0.33	1.78	0.08
BS030	1.625	1 3/4	1/16	1.614	0.013	0.07	0.003	41	0.33	1.78	0.08
BS031	1 3/4	1 7/8	1/16	1.739	0.015	0.07	0.003	44.17	0.38	1.78	0.08
BS032	1 7/8	2	1/16	1.864	0.015	0.07	0.003	47.35	0.38	1.78	0.08
BS033	2	2 1/8	1/16	1.989	0.018	0.07	0.003	50.52	0.46	1.78	0.08
BS034	2 1/8	2 1/4	1/16	2.114	0.018	0.07	0.003	53.7	0.46	1.78	0.08
BS035	2 1/4	2 3/8	1/16	2.239	0.018	0.07	0.003	56.87	0.46	1.78	0.08
BS036	2 3/8	2 1/2	1/16	2.364	0.018	0.07	0.003	60.05	0.46	1.78	0.08
BS037	2 1/2	2 5/8	1/16	2.489	0.018	0.07	0.003	63.22	0.46	1.78	0.08
BS038	2 5/8	2 3/4	1/16	2.614	0.02	0.07	0.003	66.4	0.51	1.78	0.08
BS039	2 3/4	2 7/8	1/16	2.739	0.02	0.07	0.003	69.57	0.51	1.78	0.08
BS040	2 7/8	3	1/16	2.864	0.02	0.07	0.003	72.75	0.51	1.78	0.08
BS041	3	3 1/8	1/16	2.989	0.024	0.07	0.003	75.92	0.61	1.78	0.08
BS042	3 1/4	3 3/8	1/16	3.239	0.024	0.07	0.003	82.27	0.61	1.78	0.08
BS043	3 1/2	3 5/8	1/16	3.489	0.024	0.07	0.003	88.62	0.61	1.78	0.08
BS044	3 3/4	3 7/8	1/16	3.739	0.027	0.07	0.003	94.97	0.69	1.78	0.08
BS045	4	4 1/8	1/16	3.989	0.027	0.07	0.003	101.32	0.69	1.78	0.08
BS046	4 1/4	4 3/8	1/16	4.239	0.03	0.07	0.003	107.67	0.76	1.78	0.08
BS047	4 1/2	4 3/8	1/16	4.489	0.03	0.07	0.003	114.02	0.76	1.78	0.08
BS048	4 3/4	4 7/8	1/16	4.739	0.03	0.07	0.003	120.37	0.76	1.78	0.08
BS049	5	5 1/8	1/16	4.989	0.037	0.07	0.003	126.72	0.94	1.78	0.08

BS Series O-Rings (NBR - 70 Duro)

SIZE	Nominal (Reference)			Measurement (Inch)				Measurement (mm)			
	ID	OD	CS	ID	±	CS	±	ID	±	CS	±
BS050	5 1/4	5 3/8	1/16	5.239	0.037	0.07	0.003	133.07	0.94	1.78	0.08
BS102	1/16	1/4	3/32	0.049	0.005	0.103	0.003	1.24	0.13	2.62	0.08
BS103	3/32	9/32	3/32	0.081	0.005	0.103	0.003	2.06	0.13	2.62	0.08
BS104	1/8	5/16	3/32	0.112	0.005	0.103	0.003	2.84	0.13	2.62	0.08
BS105	5/32	11/32	3/32	0.143	0.005	0.103	0.003	3.63	0.13	2.62	0.08
BS106	3/16	3/8	3/32	0.174	0.005	0.103	0.003	4.42	0.13	2.62	0.08
BS107	7/32	13/32	3/32	0.206	0.005	0.103	0.003	5.23	0.13	2.62	0.08
BS108	1/4	7/16	3/32	0.237	0.005	0.103	0.003	6.02	0.13	2.62	0.08
BS109	5/16	1/2	3/32	0.299	0.005	0.103	0.003	7.59	0.13	2.62	0.08
BS110	3/8	9/16	3/32	0.362	0.005	0.103	0.003	9.19	0.13	2.62	0.08
BS111	7/16	5/8	3/32	0.424	0.005	0.103	0.003	10.77	0.13	2.62	0.08
BS112	1/2	11/16	3/32	0.487	0.005	0.103	0.003	12.37	0.13	2.62	0.08
BS113	9/16	3/4	3/32	0.549	0.007	0.103	0.003	13.94	0.18	2.62	0.08
BS114	5/8	13/16	3/32	0.612	0.009	0.103	0.003	15.54	0.23	2.62	0.08
BS115	11/16	7/8	3/32	0.674	0.009	0.103	0.003	17.12	0.23	2.62	0.08
BS116	3/4	15/16	3/32	0.737	0.009	0.103	0.003	18.72	0.23	2.62	0.08
BS117	13/16	1	3/32	0.799	0.01	0.103	0.003	20.29	0.25	2.62	0.08
BS118	44050	1 1/16	3/32	0.862	0.01	0.103	0.003	21.89	0.25	2.62	0.08
BS119	15/16	1 1/8	3/32	0.924	0.01	0.103	0.003	23.47	0.25	2.62	0.08
BS120	1	13/16	3/32	0.987	0.01	0.103	0.003	25.07	0.25	2.62	0.08
BS121	1.0625	1 1/4	3/32	1.049	0.01	0.103	0.003	26.64	0.25	2.62	0.08
BS122	1.125	1 5/16	3/32	1.112	0.01	0.103	0.003	28.24	0.25	2.62	0.08
BS123	1.1875	1 3/8	3/32	1.174	0.012	0.103	0.003	29.82	0.3	2.62	0.08
BS124	1.25	1 7/16	3/32	1.237	0.012	0.103	0.003	31.42	0.3	2.62	0.08
BS125	1.3125	1 1/2	3/32	1.299	0.012	0.103	0.003	32.99	0.3	2.62	0.08
BS126	1.375	1 9/16	3/32	1.362	0.012	0.103	0.003	34.59	0.3	2.62	0.08
BS127	1.4375	1 5/8	3/32	1.424	0.012	0.103	0.003	36.17	0.3	2.62	0.08
BS128	1.5	1 11/16	3/32	1.487	0.012	0.103	0.003	37.77	0.3	2.62	0.08
BS129	1.5625	1 3/4	3/32	1.549	0.015	0.103	0.003	39.34	0.38	2.62	0.08
BS130	1.625	1 13/16	3/32	1.612	0.015	0.103	0.003	40.94	0.38	2.62	0.08
BS131	1 11/16	1 7/8	3/32	1.674	0.015	0.103	0.003	42.52	0.38	2.62	0.08
BS132	1 3/4	1 15/16	3/32	1.737	0.015	0.103	0.003	44.12	0.38	2.62	0.08
BS133	1 13/16	2	3/32	1.799	0.015	0.103	0.003	45.69	0.38	2.62	0.08
BS134	1 7/8	2 1/16	3/32	1.862	0.015	0.103	0.003	47.29	0.38	2.62	0.08
BS135	1 15/16	2 1/8	3/32	1.925	0.017	0.103	0.003	48.9	0.43	2.62	0.08
BS136	2	2 3/16	3/32	1.987	0.017	0.103	0.003	50.47	0.43	2.62	0.08
BS137	2 1/16	2 1/4	3/32	2.05	0.017	0.103	0.003	52.07	0.43	2.62	0.08
BS138	2 1/8	2 5/16	3/32	2.112	0.017	0.103	0.003	53.64	0.43	2.62	0.08
BS139	2 3/16	2 3/8	3/32	2.175	0.017	0.103	0.003	55.25	0.43	2.62	0.08
BS140	2 1/4	2 7/16	3/32	2.237	0.017	0.103	0.003	56.82	0.43	2.62	0.08
BS141	2 5/16	2 1/2	3/32	2.3	0.02	0.103	0.003	58.42	0.51	2.62	0.08
BS142	2 3/8	2 9/16	3/32	2.362	0.02	0.103	0.003	59.99	0.51	2.62	0.08
BS143	2 7/16	2 5/8	3/32	2.425	0.02	0.103	0.003	61.6	0.51	2.62	0.08
BS144	2 1/2	2 11/16	3/32	2.487	0.02	0.103	0.003	63.17	0.51	2.62	0.08
BS145	2 9/16	2 3/4	3/32	2.55	0.02	0.103	0.003	64.77	0.51	2.62	0.08
BS146	2 5/8	2 13/16	3/32	2.612	0.02	0.103	0.003	66.34	0.51	2.62	0.08
BS147	2 11/16	2 7/8	3/32	2.675	0.022	0.103	0.003	67.95	0.56	2.62	0.08
BS148	2 3/4	2 15/16	3/32	2.737	0.022	0.103	0.003	69.52	0.56	2.62	0.08
BS149	2 13/16	3	3/32	2.8	0.022	0.103	0.003	71.12	0.56	2.62	0.08

BS Series O-Rings (NBR - 70 Duro)

SIZE	Nominal (Reference)			Measurement (Inch)				Measurement (mm)			
	ID	OD	CS	ID	±	CS	±	ID	±	CS	±
BS150	2 7/8	3 1/16	3/32	2.862	0.022	0.103	0.003	72.69	0.56	2.62	0.08
BS151	3	3 3/16	3/32	2.987	0.024	0.103	0.003	75.87	0.61	2.62	0.08
BS152	3 1/4	3 7/16	3/32	3.237	0.024	0.103	0.003	82.22	0.61	2.62	0.08
BS153	3 1/2	3 11/16	3/32	3.487	0.024	0.103	0.003	88.57	0.61	2.62	0.08
BS154	3 3/4	3 15/16	3/32	3.737	0.028	0.103	0.003	94.92	0.71	2.62	0.08
BS155	4	4 3/16	3/32	3.987	0.028	0.103	0.003	101.27	0.71	2.62	0.08
BS156	4 1/4	4 7/16	3/32	4.237	0.03	0.103	0.003	107.62	0.76	2.62	0.08
BS157	4 1/2	4 11/16	3/32	4.487	0.03	0.103	0.003	113.97	0.76	2.62	0.08
BS158	4 3/4	4 15/16	3/32	4.737	0.03	0.103	0.003	120.32	0.76	2.62	0.08
BS159	5	5 3/16	3/32	4.987	0.035	0.103	0.003	126.67	0.89	2.62	0.08
BS160	5 1/4	5 7/16	3/32	5.237	0.035	0.103	0.003	133.02	0.89	2.62	0.08
BS161	5 1/2	5 11/16	3/32	5.487	0.035	0.103	0.003	139.37	0.89	2.62	0.08
BS162	5 3/4	5 15/16	3/32	5.737	0.035	0.103	0.003	145.72	0.89	2.62	0.08
BS163	6	6 3/16	3/32	5.987	0.035	0.103	0.003	152.07	0.89	2.62	0.08
BS164	6 1/4	6 7/16	3/32	6.237	0.04	0.103	0.003	158.42	1.02	2.62	0.08
BS165	6 1/2	6 11/16	3/32	6.487	0.04	0.103	0.003	164.77	1.02	2.62	0.08
BS166	6 3/4	6 15/16	3/32	6.737	0.04	0.103	0.003	171.12	1.02	2.62	0.08
BS167	7	7 3/16	3/32	6.987	0.04	0.103	0.003	177.47	1.02	2.62	0.08
BS168	7 1/4	7 7/16	3/32	7.237	0.045	0.103	0.003	183.82	1.14	2.62	0.08
BS169	7 1/2	7 11/16	3/32	7.487	0.045	0.103	0.003	190.17	1.14	2.62	0.08
BS170	7 3/4	7 15/16	3/32	7.737	0.045	0.103	0.003	196.52	1.14	2.62	0.08
BS171	8	8 3/16	3/32	7.987	0.045	0.103	0.003	202.87	1.14	2.62	0.08
BS172	8 1/4	8 7/16	3/32	8.237	0.05	0.103	0.003	209.22	1.27	2.62	0.08
BS173	8 1/2	8 11/16	3/32	8.487	0.05	0.103	0.003	215.57	1.27	2.62	0.08
BS174	8 3/4	8 15/16	3/32	8.737	0.05	0.103	0.003	221.92	1.27	2.62	0.08
BS175	9	9 3/16	3/32	8.987	0.05	0.103	0.003	228.27	1.27	2.62	0.08
BS176	9 1/4	9 7/16	3/32	9.237	0.055	0.103	0.003	234.62	1.4	2.62	0.08
BS177	9 1/2	9 11/16	3/32	9.487	0.055	0.103	0.003	240.97	1.4	2.62	0.08
BS178	9 3/4	9 15/16	3/32	9.737	0.055	0.103	0.003	247.32	1.4	2.62	0.08
BS201	3/16	7/16	1/8	0.171	0.005	0.139	0.004	4.34	0.13	3.53	0.1
BS202	1/4	1/2	1/8	0.234	0.005	0.139	0.004	5.94	0.13	3.53	0.1
BS203	5/16	9/16	1/8	0.296	0.005	0.139	0.004	7.52	0.13	3.53	0.1
BS204	3/8	5/8	1/8	0.359	0.005	0.139	0.004	9.12	0.13	3.53	0.1
BS205	7/16	11/16	1/8	0.421	0.005	0.139	0.004	10.69	0.13	3.53	0.1
BS206	1/2	3/4	1/8	0.484	0.005	0.139	0.004	12.29	0.13	3.53	0.1
BS207	9/16	13/16	1/8	0.546	0.007	0.139	0.004	13.87	0.18	3.53	0.1
BS208	5/8	7/8	1/8	0.609	0.009	0.139	0.004	15.47	0.23	3.53	0.1
BS209	11/16	15/16	1/8	0.671	0.009	0.139	0.004	17.04	0.23	3.53	0.1
BS210	3/4	1	1/8	0.734	0.01	0.139	0.004	18.64	0.25	3.53	0.1
BS211	13/16	1 1/16	1/8	0.796	0.01	0.139	0.004	20.22	0.25	3.53	0.1
BS212	44050	1 1/8	1/8	0.859	0.01	0.139	0.004	21.82	0.25	3.53	0.1
BS213	15/16	1 3/16	1/8	0.921	0.01	0.139	0.004	23.39	0.25	3.53	0.1
BS214	1	1 1/4	1/8	0.984	0.01	0.139	0.004	24.99	0.25	3.53	0.1
BS215	1.0625	1 5/16	1/8	1.046	0.01	0.139	0.004	26.57	0.25	3.53	0.1
BS216	1.125	1 3/8	1/8	1.109	0.012	0.139	0.004	28.17	0.3	3.53	0.1
BS217	1.1875	1 7/16	1/8	1.171	0.012	0.139	0.004	29.74	0.3	3.53	0.1
BS218	1.25	1 1/2	1/8	1.234	0.012	0.139	0.004	31.34	0.3	3.53	0.1
BS219	1.3125	1 9/16	1/8	1.296	0.012	0.139	0.004	32.92	0.3	3.53	0.1
BS220	1.375	1 5/8	1/8	1.359	0.012	0.139	0.004	34.52	0.3	3.53	0.1

BS Series O-Rings (NBR - 70 Duro)

SIZE	Nominal (Reference)			Measurement (Inch)				Measurement (mm)			
	ID	OD	CS	ID	±	CS	±	ID	±	CS	±
BS221	1.4375	1 11/16	1/8	1.421	0.012	0.139	0.004	36.09	0.3	3.53	0.1
BS222	1.5	1 3/4	1/8	1.484	0.015	0.139	0.004	37.69	0.38	3.53	0.1
BS223	1 5/8	1 7/8	1/8	1.609	0.015	0.139	0.004	40.87	0.38	3.53	0.1
BS224	1 3/4	2	1/8	1.734	0.015	0.139	0.004	44.04	0.38	3.53	0.1
BS225	1 7/8	2 1/8	1/8	1.859	0.018	0.139	0.004	47.22	0.46	3.53	0.1
BS226	2	2 1/4	1/8	1.984	0.018	0.139	0.004	50.39	0.46	3.53	0.1
BS227	2 1/16	2 3/8	1/8	2.109	0.018	0.139	0.004	53.57	0.46	3.53	0.1
BS228	2 1/4	2 1/2	1/8	2.234	0.02	0.139	0.004	56.74	0.51	3.53	0.1
BS229	2 3/8	2 5/8	1/8	2.359	0.02	0.139	0.004	59.92	0.51	3.53	0.1
BS230	2 1/2	2 3/4	1/8	2.484	0.02	0.139	0.004	63.09	0.51	3.53	0.1
BS231	2 5/8	2 7/8	1/8	2.609	0.02	0.139	0.004	66.27	0.51	3.53	0.1
BS232	2 3/4	3	1/8	2.734	0.024	0.139	0.004	69.44	0.61	3.53	0.1
BS233	2 7/8	3 1/8	1/8	2.859	0.024	0.139	0.004	72.62	0.61	3.53	0.1
BS234	3	3 1/4	1/8	2.984	0.024	0.139	0.004	75.79	0.61	3.53	0.1
BS235	3 1/8	3 3/8	1/8	3.109	0.024	0.139	0.004	78.97	0.61	3.53	0.1
BS236	3 1/4	3 1/2	1/8	3.234	0.024	0.139	0.004	82.14	0.61	3.53	0.1
BS237	3 3/8	3 5/8	1/8	3.359	0.024	0.139	0.004	85.32	0.61	3.53	0.1
BS238	3 1/2	3 3/4	1/8	3.484	0.024	0.139	0.004	88.49	0.61	3.53	0.1
BS239	3 5/8	3 7/8	1/8	3.609	0.028	0.139	0.004	91.67	0.71	3.53	0.1
BS240	3 3/4	4	1/8	3.734	0.028	0.139	0.004	94.84	0.71	3.53	0.1
BS241	3 7/8	4 1/8	1/8	3.859	0.028	0.139	0.004	98.02	0.71	3.53	0.1
BS242	4	4 1/4	1/8	3.984	0.028	0.139	0.004	101.19	0.71	3.53	0.1
BS243	4 1/8	4 3/8	1/8	4.109	0.028	0.139	0.004	104.37	0.71	3.53	0.1
BS244	4 1/4	4 1/2	1/8	4.234	0.030	0.139	0.004	107.54	0.76	3.53	0.1
BS245	4 3/8	4 5/8	1/8	4.359	0.030	0.139	0.004	110.72	0.76	3.53	0.1
BS246	4 1/2	4 3/4	1/8	4.484	0.030	0.139	0.004	113.89	0.76	3.53	0.1
BS247	4 5/8	4 7/8	1/8	4.609	0.030	0.139	0.004	117.07	0.76	3.53	0.1
BS248	4 3/4	5	1/8	4.734	0.030	0.139	0.004	120.24	0.76	3.53	0.1
BS249	4 7/8	5 1/8	1/8	4.859	0.035	0.139	0.004	123.42	0.89	3.53	0.1
BS250	5	5 1/4	1/8	4.984	0.035	0.139	0.004	126.59	0.89	3.53	0.1
BS251	5 1/8	5 3/8	1/8	5.109	0.035	0.139	0.004	129.77	0.89	3.53	0.1
BS252	5 1/4	5 1/2	1/8	5.234	0.035	0.139	0.004	132.94	0.89	3.53	0.1
BS253	5 3/8	5 5/8	1/8	5.359	0.035	0.139	0.004	136.12	0.89	3.53	0.1
BS254	5 1/2	5 3/4	1/8	5.484	0.035	0.139	0.004	139.29	0.89	3.53	0.1
BS255	5 5/8	5 7/8	1/8	5.609	0.035	0.139	0.004	142.47	0.89	3.53	0.1
BS256	5 3/4	6	1/8	5.734	0.035	0.139	0.004	145.64	0.89	3.53	0.1
BS257	5 7/8	6 1/8	1/8	5.859	0.035	0.139	0.004	148.82	0.89	3.53	0.1
BS258	6	6 1/4	1/8	5.984	0.035	0.139	0.004	151.99	0.89	3.53	0.1
BS259	6 1/4	6 1/2	1/8	6.234	0.040	0.139	0.004	158.34	1.02	3.53	0.1
BS260	6 1/2	6 3/4	1/8	6.484	0.040	0.139	0.004	164.69	1.02	3.53	0.1
BS261	6 3/4	7	1/8	6.734	0.040	0.139	0.004	171.04	1.02	3.53	0.1
BS262	7	7 1/4	1/8	6.984	0.040	0.139	0.004	177.39	1.02	3.53	0.1
BS263	7 1/4	7 1/2	1/8	7.234	0.045	0.139	0.004	183.74	1.14	3.53	0.1
BS264	7 1/2	7 3/4	1/8	7.484	0.045	0.139	0.004	190.09	1.14	3.53	0.1
BS265	7 3/4	8	1/8	7.734	0.045	0.139	0.004	196.44	1.14	3.53	0.1
BS266	8	8 1/4	1/8	7.984	0.045	0.139	0.004	202.79	1.14	3.53	0.1
BS267	8 1/4	8 1/2	1/8	8.234	0.050	0.139	0.004	209.14	1.27	3.53	0.1
BS268	8 1/2	8 3/4	1/8	8.484	0.050	0.139	0.004	215.49	1.27	3.53	0.1
BS269	8 3/4	9	1/8	8.734	0.050	0.139	0.004	221.84	1.27	3.53	0.1

BS Series O-Rings (NBR - 70 Duro)

SIZE	Nominal (Reference)			Measurement (Inch)				Measurement (mm)			
	ID	OD	CS	ID	±	CS	±	ID	±	CS	±
BS270	9	9 1/4	1/8	8.984	0.050	0.139	0.004	228.19	1.27	3.53	0.1
BS271	9 1/4	9 1/2	1/8	9.234	0.055	0.139	0.004	234.54	1.4	3.53	0.1
BS272	9 1/2	9 3/4	1/8	9.484	0.055	0.139	0.004	240.89	1.4	3.53	0.1
BS273	9 3/4	10	1/8	9.734	0.055	0.139	0.004	247.24	1.4	3.53	0.1
BS274	10	10 1/4	1/8	9.984	0.055	0.139	0.004	253.59	1.4	3.53	0.1
BS275	10 1/2	10 3/4	1/8	10.484	0.055	0.139	0.004	266.29	1.4	3.53	0.1
BS276	11	11 1/4	1/8	10.984	0.065	0.139	0.004	278.99	1.65	3.53	0.1
BS277	11 1/2	11 3/4	1/8	11.484	0.065	0.139	0.004	291.69	1.65	3.53	0.1
BS278	12	12 1/4	1/8	11.984	0.065	0.139	0.004	304.39	1.65	3.53	0.1
BS279	13	13 1/4	1/8	12.984	0.065	0.139	0.004	329.79	1.65	3.53	0.1
BS280	14	14 1/4	1/8	13.984	0.065	0.139	0.004	355.19	1.65	3.53	0.1
BS281	15	15 1/4	1/8	14.984	0.065	0.139	0.004	380.59	1.65	3.53	0.1
BS282	16	16 1/4	1/8	15.955	0.075	0.139	0.004	405.26	1.91	3.53	0.1
BS283	17	17 1/4	1/8	16.955	0.080	0.139	0.004	430.66	2.03	3.53	0.1
BS284	18	18 1/4	1/8	17.955	0.085	0.139	0.004	456.06	2.16	3.53	0.1
BS309	7/16	13/16	3/16	0.412	0.005	0.210	0.005	10.46	0.13	5.33	0.13
BS310	1/2	7/8	3/16	0.475	0.005	0.210	0.005	12.07	0.13	5.33	0.13
BS311	9/16	15/16	3/16	0.537	0.007	0.210	0.005	13.64	0.18	5.33	0.13
BS312	5/8	1	3/16	0.600	0.009	0.210	0.005	15.24	0.23	5.33	0.13
BS313	11/16	1 1/16	3/16	0.662	0.009	0.210	0.005	16.81	0.23	5.33	0.13
BS314	3/4	1 1/8	3/16	0.725	0.010	0.210	0.005	18.42	0.25	5.33	0.13
BS315	13/16	1 3/16	3/16	0.787	0.010	0.210	0.005	19.99	0.25	5.33	0.13
BS316	44050	1 1/4	3/16	0.850	0.010	0.210	0.005	21.59	0.25	5.33	0.13
BS317	15/16	1 5/16	3/16	0.912	0.010	0.210	0.005	23.16	0.25	5.33	0.13
BS318	1	1 3/8	3/16	0.975	0.010	0.210	0.005	24.77	0.25	5.33	0.13
BS319	1.0625	1 7/16	3/16	1.037	0.010	0.210	0.005	26.34	0.25	5.33	0.13
BS320	1.125	1 1/2	3/16	1.100	0.012	0.210	0.005	27.94	0.3	5.33	0.13
BS321	1.1875	1 9/16	3/16	1.162	0.012	0.210	0.005	29.51	0.3	5.33	0.13
BS322	1.25	1 5/8	3/16	1.225	0.012	0.210	0.005	31.12	0.3	5.33	0.13
BS323	1.3125	1 11/16	3/16	1.287	0.012	0.210	0.005	32.69	0.3	5.33	0.13
BS324	1.375	1 3/4	3/16	1.350	0.012	0.210	0.005	34.29	0.3	5.33	0.13
BS325	1.5	1 7/8	3/16	1.475	0.015	0.210	0.005	37.47	0.38	5.33	0.13
BS326	1 5/8	2	3/16	1.600	0.015	0.210	0.005	40.64	0.38	5.33	0.13
BS327	1 3/4	2 1/8	3/16	1.725	0.015	0.210	0.005	43.82	0.38	5.33	0.13
BS328	1 7/8	2 1/4	3/16	1.850	0.015	0.210	0.005	46.99	0.38	5.33	0.13
BS329	2	2 3/8	3/16	1.975	0.018	0.210	0.005	50.17	0.46	5.33	0.13
BS330	2 1/8	2 1/2	3/16	2.100	0.018	0.210	0.005	53.34	0.46	5.33	0.13
BS331	2 1/4	2 5/8	3/16	2.225	0.018	0.210	0.005	56.52	0.46	5.33	0.13
BS332	2 3/8	2 3/4	3/16	2.350	0.018	0.210	0.005	59.69	0.46	5.33	0.13
BS333	2 1/2	2 7/8	3/16	2.475	0.020	0.210	0.005	62.87	0.51	5.33	0.13
BS334	2 5/8	3	3/16	2.600	0.020	0.210	0.005	66.04	0.51	5.33	0.13
BS335	2 3/4	3 1/8	3/16	2.725	0.020	0.210	0.005	69.22	0.51	5.33	0.13
BS336	2 7/8	3 1/4	3/16	2.850	0.020	0.210	0.005	72.39	0.51	5.33	0.13
BS337	3	3 3/8	3/16	2.975	0.024	0.210	0.005	75.57	0.61	5.33	0.13
BS338	3 1/8	3 1/2	3/16	3.100	0.024	0.210	0.005	78.74	0.61	5.33	0.13
BS339	3 1/4	3 5/8	3/16	3.225	0.024	0.210	0.005	81.92	0.61	5.33	0.13
BS340	3 3/8	3 3/4	3/16	3.350	0.024	0.210	0.005	85.09	0.61	5.33	0.13
BS341	3 1/2	3 7/8	3/16	3.475	0.024	0.210	0.005	88.27	0.61	5.33	0.13
BS342	3 5/8	4	3/16	3.600	0.028	0.210	0.005	91.44	0.71	5.33	0.13

BS Series O-Rings (NBR - 70 Duro)

SIZE	Nominal (Reference)			Measurement (Inch)				Measurement (mm)			
	ID	OD	CS	ID	±	CS	±	ID	±	CS	±
BS343	3 3/4	4 1/8	3/16	3.725	0.028	0.210	0.005	94.62	0.71	5.33	0.13
BS344	3 7/8	4 1/4	3/16	3.850	0.028	0.210	0.005	97.79	0.71	5.33	0.13
BS345	4	4 3/8	3/16	3.975	0.028	0.210	0.005	100.97	0.71	5.33	0.13
BS346	4 1/8	4 1/2	3/16	4.100	0.028	0.210	0.005	104.14	0.71	5.33	0.13
BS347	4 1/4	4 5/8	3/16	4.225	0.030	0.210	0.005	107.32	0.76	5.33	0.13
BS348	4 3/8	4 3/4	3/16	4.350	0.030	0.210	0.005	110.49	0.76	5.33	0.13
BS349	4 1/2	4 7/8	3/16	4.475	0.030	0.210	0.005	113.67	0.76	5.33	0.13
BS350	4 5/8	5	3/16	4.600	0.030	0.210	0.005	116.84	0.76	5.33	0.13
BS425	4 1/2	5	1/4	4.475	0.033	0.275	0.006	113.67	0.84	6.99	0.15
BS426	4 5/8	5 1/8	1/4	4.600	0.033	0.275	0.006	116.84	0.84	6.99	0.15
BS427	4 3/4	5 1/4	1/4	4.725	0.033	0.275	0.006	120.02	0.84	6.99	0.15
BS428	4 7/8	5 3/8	1/4	4.85	0.033	0.275	0.006	123.19	0.84	6.99	0.15
BS429	5	5 1/2	1/4	4.975	0.037	0.275	0.006	126.37	0.94	6.99	0.15
BS430	5 1/8	5 5/8	1/4	5.100	0.037	0.275	0.006	129.54	0.94	6.99	0.15
BS431	5 1/4	5 3/4	1/4	5.225	0.037	0.275	0.006	132.72	0.94	6.99	0.15
BS432	5 3/8	5 7/8	1/4	5.350	0.037	0.275	0.006	135.89	0.94	6.99	0.15
BS433	5 1/2	6	1/4	5.475	0.037	0.275	0.006	139.07	0.94	6.99	0.15
BS434	5 5/8	6 1/8	1/4	5.600	0.037	0.275	0.006	142.24	0.94	6.99	0.15
BS435	5 3/4	6 1/4	1/4	5.725	0.037	0.275	0.006	145.42	0.94	6.99	0.15
BS436	5 7/8	6 3/8	1/4	5.850	0.037	0.275	0.006	148.59	0.94	6.99	0.15
BS437	6	6 1/2	1/4	5.975	0.037	0.275	0.006	151.77	0.94	6.99	0.15
BS438	6 1/4	6 3/4	1/4	6.225	0.040	0.275	0.006	158.12	1.02	6.99	0.15
BS439	6 1/2	7	1/4	6.475	0.040	0.275	0.006	164.47	1.02	6.99	0.15
BS440	6 3/4	7 1/4	1/4	6.725	0.040	0.275	0.006	170.82	1.02	6.99	0.15
BS441	7	7 1/2	1/4	6.975	0.040	0.275	0.006	177.17	1.02	6.99	0.15
BS442	7 1/4	7 3/4	1/4	7.225	0.045	0.275	0.006	183.52	1.14	6.99	0.15
BS443	7 1/2	8	1/4	7.475	0.045	0.275	0.006	189.87	1.14	6.99	0.15
BS444	7 3/4	8 1/4	1/4	7.725	0.045	0.275	0.006	196.22	1.14	6.99	0.15
BS445	8	8 1/2	1/4	7.975	0.045	0.275	0.006	202.57	1.14	6.99	0.15
BS446	8 1/2	9	1/4	8.475	0.055	0.275	0.006	215.27	1.4	6.99	0.15
BS447	9	9 1/2	1/4	8.975	0.055	0.275	0.006	227.97	1.4	6.99	0.15
BS448	9 1/2	10	1/4	9.475	0.055	0.275	0.006	240.67	1.4	6.99	0.15
BS449	10	10 1/2	1/4	9.975	0.055	0.275	0.006	253.37	1.4	6.99	0.15
BS450	10 1/2	11	1/4	10.475	0.06	0.275	0.006	266.07	1.52	6.99	0.15
BS451	11	11 1/2	1/4	10.975	0.06	0.275	0.006	278.77	1.52	6.99	0.15
BS452	11 1/2	12	1/4	11.475	0.06	0.275	0.006	291.47	1.52	6.99	0.15
BS453	12	12 1/2	1/4	11.975	0.06	0.275	0.006	304.17	1.52	6.99	0.15
BS454	12 1/2	13	1/4	12.475	0.06	0.275	0.006	316.87	1.52	6.99	0.15
BS455	13	13 1/2	1/4	12.975	0.06	0.275	0.006	329.57	1.52	6.99	0.15
BS456	13 1/2	14	1/4	13.475	0.07	0.275	0.006	342.27	1.78	6.99	0.15
BS457	14	14 1/2	1/4	13.975	0.07	0.275	0.006	354.97	1.78	6.99	0.15
BS458	14 1/2	15	1/4	14.475	0.07	0.275	0.006	367.67	1.78	6.99	0.15
BS459	15	15 1/2	1/4	14.975	0.07	0.275	0.006	380.37	1.78	6.99	0.15
BS460	15 1/2	16	1/4	15.475	0.07	0.275	0.006	393.07	1.78	6.99	0.15
BS461	16	16 1/2	1/4	15.955	0.075	0.275	0.006	405.26	1.91	6.99	0.15
BS462	16 1/2	17	1/4	16.455	0.075	0.275	0.006	417.96	1.91	6.99	0.15
BS463	17	17 1/2	1/4	16.955	0.08	0.275	0.006	430.66	2.03	6.99	0.15
BS464	17 1/2	18	1/4	17.455	0.085	0.275	0.006	443.36	2.16	6.99	0.15
BS465	18	18 1/2	1/4	17.955	0.085	0.275	0.006	456.06	2.16	6.99	0.15

BS Series O-Rings (NBR - 70 Duro)

SIZE	Nominal (Reference)			Measurement (Inch)				Measurement (mm)			
	ID	OD	CS	ID	±	CS	±	ID	±	CS	±
BS466	18 1/2	19	1/4	18.455	0.085	0.275	0.006	468.76	2.16	6.99	0.15
BS467	19	19 1/2	1/4	18.955	0.09	0.275	0.006	481.46	2.29	6.99	0.15
BS468	19 1/2	20	1/4	19.455	0.09	0.275	0.006	494.16	2.29	6.99	0.15
BS469	20	20 1/2	1/4	19.955	0.095	0.275	0.006	506.86	2.41	6.99	0.15
BS470	21	21 1/2	1/4	20.955	0.095	0.275	0.006	532.26	2.41	6.99	0.15
BS471	22	22 1/2	1/4	21.955	0.1	0.275	0.006	557.66	2.54	6.99	0.15
BS472	23	23 1/2	1/4	22.94	0.105	0.275	0.006	582.68	2.67	6.99	0.15
BS473	24	24 1/2	1/4	23.94	0.11	0.275	0.006	608.08	2.79	6.99	0.15
BS474	25	25 1/2	1/4	24.94	0.115	0.275	0.006	633.48	2.92	6.99	0.15
BS475	26	26 1/2	1/4	25.94	0.12	0.275	0.006	658.88	3.05	6.99	0.15

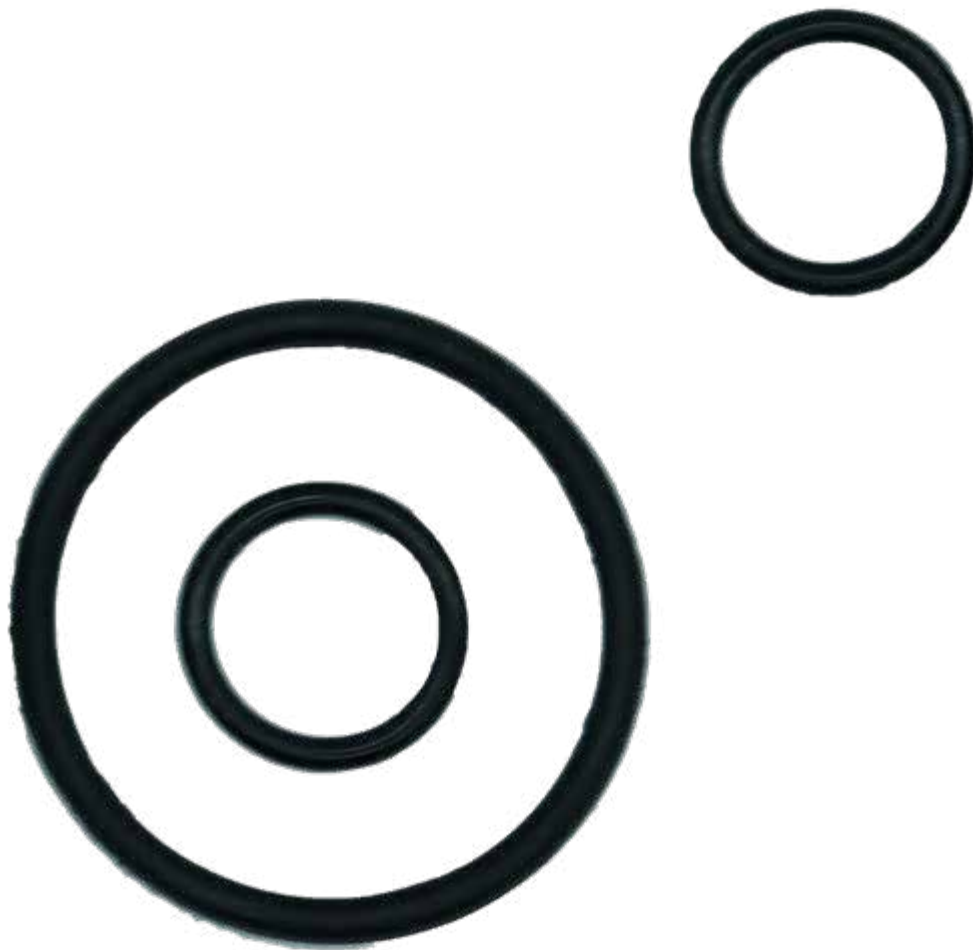

Metric Series O-Rings (NBR - 70 Duro)

SIZE	Measurements (mm)				Measurements (Inch)			
	ID	±	CS	±	ID	±	CS	±
MOR1 x 1	1.00	0.12	1.00	0.07	0.039	0.005	0.039	0.003
MOR1 x 2	1.00	0.12	2.00	0.08	0.005	0.079	0.002	0.000
MOR1.5 x 1	1.50	0.12	1.00	0.07	0.059	0.005	0.039	0.003
MOR1.5 x 1.5	1.50	0.12	1.50	0.08	0.059	0.005	0.059	0.003
MOR2 x 1	2.00	0.13	1.00	0.07	0.079	0.005	0.039	0.003
MOR2 x 1.5	2.00	0.13	1.50	0.08	0.079	0.005	0.059	0.003
MOR2 x 2	2.00	0.13	2.00	0.08	0.079	0.005	0.079	0.003
MOR2.5 x 2	2.50	0.13	2.00	0.08	0.098	0.005	0.079	0.003
MOR3 x 1	3.00	0.14	1.00	0.07	0.118	0.006	0.039	0.003
MOR3 x 1.5	3.00	0.14	1.50	0.08	0.118	0.006	0.059	0.003
MOR3 x 2	3.00	0.14	2.00	0.08	0.118	0.006	0.079	0.003
MOR3 x 3	3.00	0.14	3.00	0.09	0.118	0.006	0.118	0.004
MOR3.5 x 1	3.50	0.14	1.00	0.07	0.138	0.006	0.039	0.003
MOR3X2.5	3.00	0.14	2.50	0.09	0.118	0.006	0.098	0.004
MOR4 x 1	4.00	0.14	1.00	0.07	0.158	0.006	0.039	0.003
MOR4 x 1.5	4.00	0.14	1.50	0.08	0.158	0.006	0.026	0.003
MOR4 x 2	4.00	0.14	2.00	0.08	0.158	0.006	0.079	0.003
MOR4X2.5	4.00	0.14	2.50	0.09	0.157	0.006	0.098	0.004
MOR4 x 3	4.00	0.14	3.00	0.09	0.158	0.006	0.118	0.004
MOR4 x 4	4.00	0.14	4.00	0.10	0.158	0.006	0.158	0.004
MOR5 x 1	5.00	0.15	1.00	0.07	0.197	0.006	0.039	0.003
MOR5 x 1.5	5.00	0.15	1.50	0.08	0.197	0.006	0.059	0.003
MOR5 x 2	5.00	0.15	2.00	0.08	0.197	0.006	0.079	0.003
MOR5X2.5	5.00	0.15	2.50	0.09	0.197	0.006	0.098	0.004
MOR5 x 3	5.00	0.15	3.00	0.09	0.197	0.006	0.118	0.004
MOR5X3.5	3.00	0.14	3.50	0.10	0.115	0.006	0.138	0.004
MOR5.1 x 1.6	5.10	0.15	1.60	0.08	0.201	0.006	0.063	0.003
MOR5.5 x 2	5.50	0.15	2.00	0.08	0.217	0.006	0.079	0.003
MOR5.5X2.5	5.50	0.16	2.50	0.09	0.217	0.006	0.098	0.004
MOR6 x 1	6.00	0.15	1.00	0.07	0.236	0.006	0.039	0.003
MOR6 x 1.5	6.00	0.15	1.50	0.08	0.236	0.059	0.059	0.003
MOR6 x 2	6.00	0.15	2.00	0.08	0.236	0.006	0.079	0.003
MOR6 x 3	6.00	0.15	3.00	0.09	0.236	0.006	0.118	0.004
MOR6 x 4	6.00	0.15	4.00	0.10	0.236	0.006	0.158	0.004
MOR6X2.5	6.00	0.16	2.50	0.09	0.236	0.006	0.098	0.004
MOR6.5 x 1	6.50	0.16	1.00	0.07	0.256	0.006	0.039	0.003
MOR6.5 x 2	6.50	0.16	2.00	0.08	0.256	0.006	0.079	0.003
MOR6.5X2.5	6.50	2.50	2.50	0.09	0.256	0.006	0.098	0.004
MOR6.5X3.5	6.00	0.16	3.50	0.10	0.236	0.006	0.138	0.004
MOR7 x 1	7.00	0.16	1.00	0.07	0.276	0.006	0.039	0.003
MOR7 x 1.5	7.00	0.16	1.50	0.08	0.296	0.006	0.059	0.003
MOR7 x 2	7.00	0.16	2.00	0.08	0.276	0.006	0.079	0.003
MOR7X2.5	7.00	0.17	2.50	0.09	0.276	0.007	0.098	0.004
MOR7 x 3	7.00	0.16	3.00	0.09	0.276	0.006	0.118	0.004
MOR8 x 1	8.00	0.16	1.00	0.07	0.315	0.006	0.039	0.003
MOR8 x 1.5	8.00	0.16	1.50	0.08	0.315	0.006	0.059	0.003
MOR8 x 2	8.00	0.16	2.00	0.08	0.315	0.006	0.079	0.003
MOR8X2.5	8.00	0.17	2.50	0.09	0.315	0.007	0.098	0.004
MOR8X3.5	8.00	0.17	3.50	0.10	0.315	0.007	0.138	0.004
MOR8 x 3	8.00	0.16	3.00	0.09	0.315	0.006	0.118	0.004
MOR8 x 4	8.00	0.16	4.00	0.10	0.315	0.006	0.158	0.004
MOR9 x 1	9.00	0.17	1.00	0.07	0.354	0.007	0.039	0.003

SIZE	Measurements (mm)				Measurements (Inch)			
	ID	±	CS	±	ID	±	CS	±
MOR9 x 1.5	9.00	0.17	1.50	0.08	0.354	0.007	0.059	0.003
MOR9 x 2	9.00	0.17	2.00	0.08	0.354	0.007	0.079	0.003
MOR9X2.5	9.00	0.18	2.50	0.09	0.354	0.007	0.098	0.004
MOR9 x 3	9.00	0.17	3.00	0.09	0.354	0.007	0.118	0.004
MOR10 x 1	10.00	0.17	1.00	0.07	0.394	0.007	0.039	0.003
MOR10 x 1.5	10.00	0.17	1.50	0.08	0.394	0.007	0.059	0.003
MOR10 x 2	10.00	0.17	2.00	0.08	0.394	0.007	0.079	0.003
MOR10 x 3	10.00	0.17	3.00	0.09	0.394	0.007	0.118	0.004
MOR10 x 4	10.00	0.17	4.00	0.10	0.394	0.007	0.158	0.004
MOR10.5 x 1	10.50	0.18	1.00	0.07	0.413	0.007	0.039	0.003
MOR10.5 x 3	10.50	0.18	3.00	0.09	0.413	0.007	0.118	0.004
MOR10.5X2.5	10.50	0.19	2.50	0.09	0.413	0.007	0.098	0.004
MOR10X2.5	10.00	0.19	2.50	0.09	0.394	0.007	0.098	0.004
MOR10X3.5	10.00	0.19	3.50	0.10	0.394	0.007	0.138	0.004
MOR11 x 1	11.00	0.18	1.00	0.07	0.433	0.007	0.039	0.003
MOR11 x 1.5	11.00	0.18	1.50	0.08	0.433	0.007	0.059	0.003
MOR11 x 2	11.00	0.18	2.00	0.08	0.433	0.007	0.079	0.003
MOR11 x 3	11.00	0.18	3.00	0.09	0.433	0.007	0.118	0.004
MOR11.5 x 1	11.50	0.19	1.00	0.07	0.453	0.008	0.039	0.003
MOR11.5X2.5	11.50	0.20	2.50	0.09	0.453	0.008	0.098	0.004
MOR11X2.5	11.00	0.20	2.50	0.09	0.433	0.008	0.098	0.004
MOR11X3.5	11.00	0.20	3.50	0.10	0.433	0.008	0.138	0.004
MOR12 x 1	12.00	0.19	1.00	0.07	0.472	0.008	0.039	0.003
MOR12 x 2	12.00	0.19	2.00	0.08	0.472	0.008	0.079	0.003
MOR12 x 3	12.00	0.19	3.00	0.09	0.472	0.008	0.118	0.004
MOR12 x 4	12.00	0.19	4.00	0.10	0.472	0.008	0.158	0.004
MOR12.1 x 1.6	12.10	0.19	1.60	0.08	0.476	0.008	0.063	0.003
MOR12.5 x 1	12.50	0.19	1.00	0.07	0.492	0.008	0.039	0.003
MOR12.5 x 1.5	12.50	0.19	1.50	0.08	0.492	0.008	0.059	0.003
MOR12.5 x 2	12.50	0.19	2.00	0.08	0.492	0.008	0.079	0.003
MOR12.5 x 3	12.50	0.19	3.00	0.09	0.492	0.008	0.118	0.004
MOR12X2.5	12.00	0.21	2.50	0.09	0.472	0.008	0.098	0.004
MOR12X3.5	12.00	0.21	3.50	0.10	0.472	0.008	0.138	0.004
MOR13 x 1	13.00	0.19	1.00	0.07	0.512	0.008	0.039	0.003
MOR13 x 1.5	13.00	0.19	1.50	0.08	0.552	0.008	0.059	0.003
MOR13 x 2	13.00	0.19	2.00	0.08	0.512	0.008	0.079	0.003
MOR13 x 3	13.00	0.19	3.00	0.09	0.512	0.008	0.118	0.004
MOR13.5 x 1	13.50	0.19	1.00	0.07	0.532	0.008	0.039	0.003
MOR13.5 x 2	13.50	0.19	2.00	0.08	0.532	0.008	0.079	0.003
MOR13.5 x 3	13.50	0.19	3.00	0.09	0.532	0.008	0.118	0.004
MOR13X2.5	13.00	0.21	2.50	0.09	0.512	0.008	0.098	0.004
MOR13X3.5	13.00	0.21	3.50	0.10	0.512	0.008	0.138	0.004
MOR14 x 1	14.00	0.19	1.00	0.07	0.551	0.008	0.039	0.003
MOR14 x 1.5	14.00	0.19	1.50	0.08	0.551	0.008	0.059	0.003
MOR14 x 2	14.00	0.19	2.00	0.08	0.551	0.008	0.079	0.003

Metric Series O-Rings (NBR - 70 Duro)

SIZE	Measurements (mm)				Measurements (Inch)			
	ID	±	CS	±	ID	±	CS	±
MOR14 x 3	14.00	0.19	3.00	0.09	0.551	0.008	0.118	0.004
MOR14 x 4	14.00	0.19	4.00	0.10	0.551	0.008	0.158	0.004
MOR14.1 x 1.6	14.10	0.19	1.60	0.08	0.555	0.008	0.063	0.003
MOR14.5 x 1	14.50	0.20	1.00	0.07	0.571	0.008	0.039	0.003
MOR14.5 x 2	14.50	0.20	2.00	0.08	0.571	0.008	0.079	0.003
MOR14.5 x 3	14.50	0.20	3.00	0.09	0.571	0.008	0.118	0.004
MOR14.5X2.5	14.50	0.22	2.50	0.09	0.571	0.009	0.098	0.004
MOR14X2.5	14.00	0.22	2.50	0.09	0.551	0.009	0.098	0.004
MOR15 x 1	15.00	0.20	1.00	0.07	0.591	0.008	0.039	0.003
MOR15 x 1.5	15.00	0.20	1.50	0.08	0.591	0.008	0.059	0.003
MOR15 x 2	15.00	0.20	2.00	0.08	0.591	0.008	0.079	0.003
MOR15 x 3	15.00	0.20	3.00	0.09	0.591	0.008	0.118	0.004
MOR15.1 x 1.6	15.10	0.20	1.60	0.08	0.595	0.008	0.063	0.003
MOR15X2.5	15.00	0.23	2.50	0.09	0.591	0.009	0.098	0.004
MOR15X3.5	15.00	0.23	3.50	0.10	0.591	0.009	0.138	0.004
MOR16 x 1	16.00	0.20	1.00	0.07	0.630	0.008	0.039	0.003
MOR16 x 1.5	16.00	0.20	1.50	0.08	0.630	0.008	0.059	0.003
MOR16 x 2	16.00	0.20	2.00	0.08	0.630	0.008	0.079	0.003
MOR16 x 3	16.00	0.20	3.00	0.09	0.630	0.008	0.118	0.004
MOR16 x 4	16.00	0.20	4.00	0.10	0.630	0.008	0.158	0.004
MOR16X2.5	16.00	0.24	2.50	0.09	0.630	0.009	0.098	0.004
MOR16X3.5	16.00	0.24	3.50	0.10	0.630	0.009	0.138	0.004
MOR17 x 1	17.00	0.21	1.00	0.07	0.669	0.008	0.039	0.003
MOR17 x 1.5	17.00	0.21	1.50	0.08	0.669	0.008	0.059	0.0031
MOR17 x 2	17.00	0.21	2.00	0.08	0.669	0.008	0.079	0.003
MOR17 x 3	17.00	0.21	3.00	0.09	0.669	0.008	0.118	0.004
MOR17.5 x 2	17.50	0.21	2.00	0.08	0.689	0.008	0.079	0.003
MOR17.5 x 3	17.50	0.21	3.00	0.09	0.689	0.008	0.118	0.004
MOR17X2.5	17.00	0.24	2.50	0.09	0.669	0.009	0.098	0.004
MOR18 x 1	18.00	0.21	1.00	0.07	0.709	0.008	0.039	0.003
MOR18 x 1.5	18.00	0.21	1.50	0.08	0.709	0.008	0.059	0.003
MOR18 x 2	18.00	0.21	2.00	0.08	0.709	0.008	0.079	0.003
MOR18 x 3	18.00	0.21	3.00	0.09	0.709	0.008	0.118	0.004
MOR18 x 4	18.00	0.21	4.00	0.10	0.709	0.008	0.158	0.004
MOR18.5 x 1.5	18.50	0.22	1.50	0.08	0.728	0.009	0.059	0.003
MOR18.5 x 2	18.50	0.22	2.00	0.08	0.728	0.009	0.079	0.003
MOR18.5X2.5	18.40	0.25	2.50	0.09	0.728	0.010	0.098	0.004
MOR18X2.5	18.00	0.25	2.50	0.09	0.709	0.010	0.098	0.004
MOR18X3.5	18.00	0.25	3.50	0.10	0.709	0.010	0.138	0.004
MOR19 x 1	19.00	0.22	1.00	0.07	0.748	0.009	0.039	0.003
MOR19 x 1.5	19.00	0.22	1.50	0.08	0.748	0.009	0.059	0.003
MOR19 x 2	19.00	0.22	2.00	0.08	0.748	0.009	0.079	0.003
MOR19 x 3	19.00	0.22	3.00	0.09	0.748	0.009	0.118	0.004
MOR19.5 x 3	19.50	0.22	3.00	0.09	0.768	0.009	0.118	0.004
MOR19X2.5	19.00	0.26	2.50	0.09	0.748	0.010	0.098	0.004

SIZE	Measurements (mm)				Measurements (Inch)			
	ID	±	CS	±	ID	±	CS	±
MOR19X3.5	19.00	0.26	3.50	0.10	0.748	0.010	0.138	0.004
MOR20 x 1	20.00	0.22	1.00	0.07	0.787	0.009	0.039	0.003
MOR20 x 1.5	20.00	0.22	1.50	0.08	0.787	0.009	0.059	0.003
MOR20 x 2	20.00	0.22	2.00	0.08	0.787	0.009	0.079	0.003
MOR20 x 3	20.00	0.22	3.00	0.09	0.787	0.009	0.118	0.004
MOR20 x 4	20.00	0.22	4.00	0.10	0.787	0.009	0.158	0.004
MOR20.5X3.5	20.50	0.27	3.50	0.10	0.807	0.011	0.138	0.004
MOR20X2.5	20.00	0.26	2.50	0.09	0.787	0.010	0.098	0.004
MOR20X3.5	20.00	0.26	3.50	0.10	0.787	0.010	0.138	0.004
MOR21 x 1.5	21.00	0.23	1.50	0.08	0.827	0.009	0.059	0.003
MOR21 x 2	21.00	0.23	2.00	0.08	0.827	0.009	0.079	0.003
MOR21X2.5	21.00	0.27	2.50	0.09	0.827	0.011	0.098	0.004
MOR21 x 3	21.00	0.23	3.00	0.09	0.827	0.009	0.118	0.004
MOR21.5 x 3	21.50	0.23	3.00	0.09	0.847	0.009	0.118	0.004
MOR21X3.5	21.00	0.27	3.50	0.10	0.827	0.011	0.138	0.004
MOR22 x 1	22.00	0.24	1.00	0.07	0.866	0.009	0.039	0.003
MOR22 x 1.5	22.00	0.24	1.50	0.08	0.866	0.009	0.059	0.003
MOR22 x 2	22.00	0.24	2.00	0.08	0.866	0.009	0.079	0.003
MOR22X2.5	22.00	0.28	2.50	0.09	0.866	0.011	0.098	0.004
MOR22 x 3	22.00	0.24	3.00	0.09	0.866	0.009	0.118	0.004
MOR22X3.5	22.00	0.28	3.50	0.10	0.866	0.011	0.138	0.004
MOR22 x 4	22.00	0.24	4.00	0.10	0.866	0.009	0.158	0.004
MOR23 x 1	23.00	0.24	1.00	0.07	0.906	0.009	0.039	0.003
MOR23 x 1.5	23.00	0.24	1.50	0.08	0.906	0.009	0.059	0.003
MOR23 x 2	23.00	0.24	2.00	0.08	0.906	0.009	0.079	0.003
MOR23X2.5	23.00	0.29	2.50	0.09	0.906	0.011	0.098	0.004
MOR23 x 3	23.00	0.24	3.00	0.09	0.906	0.009	0.118	0.004
MOR23X3.5	23.00	0.29	3.50	0.10	0.906	0.011	0.138	0.004
MOR24 x 1	24.00	0.24	1.00	0.07	0.945	0.009	0.039	0.003
MOR24 x 1.5	24.00	0.24	1.50	0.08	0.945	0.009	0.059	0.003
MOR24 x 2	24.00	0.24	2.00	0.08	0.945	0.009	0.079	0.003
MOR24X2.5	24.00	0.29	2.50	0.09	0.945	0.011	0.098	0.004
MOR24 x 3	24.00	0.24	3.00	0.09	0.945	0.009	0.118	0.004
MOR24X3.5	24.00	0.29	3.50	0.10	0.945	0.011	0.138	0.004
MOR24 x 4	24.00	0.24	4.00	0.10	0.945	0.009	0.158	0.004
MOR25 x 1	25.00	0.25	1.00	0.07	0.984	0.010	0.039	0.003
MOR25 x 1.5	25.00	0.25	1.50	0.08	0.984	0.010	0.059	0.003
MOR25 x 2	25.00	0.25	2.00	0.08	0.984	0.010	0.079	0.003
MOR25X2.5	25.00	0.30	2.50	0.09	0.984	0.012	0.098	0.004
MOR25 x 3	25.00	0.25	3.00	0.09	0.984	0.010	0.118	0.004
MOR25X3.5	25.00	0.30	3.50	0.10	0.984	0.012	0.138	0.004
MOR26 x 1.5	26.00	0.26	1.50	0.08	1.024	0.010	0.059	0.003
MOR26 x 2	26.00	0.26	2.00	0.08	1.024	0.010	0.079	0.003
MOR26X2.5	26.00	0.31	2.50	0.09	1.024	0.012	0.098	0.004
MOR26 x 3	26.00	0.26	3.00	0.09	1.024	0.010	0.118	0.004

Metric Series O-Rings (NBR - 70 Duro)

SIZE	Measurements (mm)				Measurements (Inch)			
	ID	±	CS	±	ID	±	CS	±
MOR26X3.5	26.00	0.31	3.50	0.10	1.024	0.012	0.138	0.004
MOR26 x 4	26.00	0.26	4.00	0.10	1.024	0.010	0.158	0.004
MOR27 x 1.5	27.00	0.26	1.50	0.08	1.063	0.010	0.059	0.003
MOR27 x 2	27.00	0.26	2.00	0.08	1.063	0.010	0.079	0.003
MOR27X2.5	27.00	0.32	2.50	0.09	1.063	0.013	0.098	0.004
MOR27 x 3	27.00	0.26	3.00	0.09	1.063	0.010	0.118	0.004
MOR27X3.5	27.00	0.32	3.50	0.10	1.063	0.013	0.138	0.004
MOR27.5 x 3	27.50	0.26	3.00	0.09	1.083	0.010	0.118	0.004
MOR28 x 1.5	28.00	0.28	1.50	0.08	1.102	0.011	0.059	0.003
MOR28 x 2	28.00	0.28	2.00	0.08	1.102	0.011	0.079	0.003
MOR28X2.5	28.00	0.32	2.50	0.09	1.102	0.013	0.098	0.004
MOR28 x 3	28.00	0.28	3.00	0.09	1.102	0.011	0.118	0.004
MOR28X3.5	28.00	0.32	3.50	0.10	1.102	0.013	0.138	0.004
MOR28 x 4	28.00	0.28	4.00	0.10	1.102	0.011	0.158	0.004
MOR29 x 1.5	29.00	0.29	1.50	0.08	1.142	0.011	0.059	0.003
MOR29 x 2	29.00	0.29	2.00	0.08	1.142	0.011	0.079	0.003
MOR29X2.5	29.00	0.33	2.50	0.09	1.142	0.013	0.098	0.004
MOR29 x 3	29.00	0.29	3.00	0.09	1.142	0.011	0.118	0.004
MOR29X3.5	29.00	0.33	3.50	0.10	1.142	0.013	0.138	0.004
MOR30 x 1.5	30.00	0.29	1.50	0.08	1.181	0.011	0.059	0.003
MOR30 x 2	30.00	0.29	2.00	0.08	1.181	0.011	0.079	0.003
MOR30X2.5	30.00	0.34	2.50	0.09	1.181	0.013	0.098	0.004
MOR30 x 3	30.00	0.29	3.00	0.09	1.181	0.011	0.118	0.004
MOR30X3.5	30.00	0.34	3.50	0.10	1.181	0.013	0.138	0.004
MOR30 x 4	30.00	0.29	4.00	0.10	1.181	0.011	0.158	0.004
MOR30 x 5	30.00	0.29	5.00	0.13	1.181	0.011	0.197	0.005
MOR31 x 1.5	31.00	0.31	1.50	0.08	1.221	0.012	0.059	0.003
MOR31X2.5	31.00	0.34	2.50	0.09	1.220	0.013	0.098	0.004
MOR31 x 3	31.00	0.31	3.00	0.09	1.221	0.012	0.118	0.004
MOR31X3.5	31.00	0.34	3.50	0.10	1.220	0.013	0.138	0.004
MOR32 x 1.5	32.00	0.32	1.50	0.08	1.260	0.013	0.059	0.003
MOR32 x 2	32.00	0.32	2.00	0.08	1.260	0.013	0.079	0.003
MOR32X2.5	32.00	0.35	2.50	0.09	1.260	0.014	0.098	0.004
MOR32 x 3	32.00	0.32	3.00	0.09	1.260	0.013	0.118	0.004
MOR32X3.5	32.00	0.35	3.50	0.10	1.260	0.014	0.138	0.004
MOR32 x 4	32.00	0.32	4.00	0.10	1.260	0.013	0.158	0.004
MOR32 x 5	32.00	0.32	5.00	0.13	1.260	0.013	0.197	0.005
MOR33 x 1.5	33.00	0.32	1.50	0.08	1.299	0.013	0.059	0.003
MOR33 x 2	33.00	0.32	2.00	0.08	1.299	0.013	0.079	0.003
MOR33X2.5	33.00	0.36	2.50	0.09	1.299	0.014	0.098	0.004
MOR33 x 3	33.00	0.32	3.00	0.09	1.299	0.013	0.118	0.004
MOR33X3.5	33.00	0.36	3.50	0.10	1.299	0.014	0.138	0.004
MOR33.5X2.5	33.50	0.36	2.50	0.09	1.319	0.014	0.098	0.004
MOR34 x 1.5	34.00	0.33	1.50	0.08	1.339	0.013	0.059	0.003
MOR34 x 2	34.00	0.33	2.00	0.08	1.339	0.013	0.079	0.003
MOR34X2.5	34.00	0.37	2.50	0.09	1.339	0.015	0.098	0.004
MOR34 x 3	34.00	0.33	3.00	0.09	1.339	0.013	0.118	0.004
MOR34X3.5	34.00	0.37	3.50	0.10	1.339	0.015	0.138	0.004
MOR34 x 4	34.00	0.33	4.00	0.10	1.339	0.013	0.158	0.004
MOR34 x 5	34.00	0.33	5.00	0.13	1.339	0.013	0.197	0.005
MOR35 x 1.5	35.00	0.34	1.50	0.08	1.378	0.013	0.059	0.003
MOR35X2.5	35.00	0.37	2.50	0.09	1.378	0.015	0.098	0.004

SIZE	Measurements (mm)				Measurements (Inch)			
	ID	±	CS	±	ID	±	CS	±
MOR35 x 3	35.00	0.34	3.00	0.09	1.378	0.013	0.118	0.004
MOR35X3.5	35.00	0.37	3.50	0.10	1.378	0.015	0.138	0.004
MOR35.5 x 3	35.50	0.34	3.00	0.09	1.398	0.013	0.118	0.004
MOR36 x 1.5	36.00	0.35	1.50	0.08	1.417	0.014	0.059	0.003
MOR36 x 2	36.00	0.35	2.00	0.08	1.417	0.014	0.079	0.003
MOR36X2.5	36.00	0.38	2.50	0.09	1.417	0.015	0.098	0.004
MOR36 x 3	36.00	0.35	3.00	0.09	1.417	0.014	0.118	0.004
MOR36 x 4	36.00	0.35	4.00	0.10	1.417	0.014	0.158	0.004
MOR36 x 5	36.00	0.35	5.00	0.13	1.417	0.014	0.197	0.005
MOR37 x 1.5	37.00	0.36	1.50	0.08	1.457	0.014	0.059	0.003
MOR37 x 2	37.00	0.36	2.00	0.08	1.457	0.014	0.079	0.003
MOR37X2.5	37.00	0.39	2.50	0.09	1.457	0.015	0.098	0.004
MOR37 x 3	37.00	0.36	3.00	0.09	1.457	0.014	0.118	0.004
MOR37X3.5	37.00	0.39	3.50	0.10	1.457	0.015	0.138	0.004
MOR38 x 1.5	38.00	0.36	1.50	0.08	1.496	0.014	0.059	0.003
MOR38 x 2	38.00	0.36	2.00	0.08	1.496	0.014	0.079	0.003
MOR38X2.5	38.00	0.40	2.50	0.09	1.496	0.016	0.098	0.004
MOR38 x 3	38.00	0.36	3.00	0.09	1.496	0.014	0.118	0.004
MOR38X3.5	38.00	0.40	3.50	0.10	1.496	0.016	0.138	0.004
MOR38 x 4	38.00	0.36	4.00	0.10	1.496	0.014	0.158	0.004
MOR38 x 5	38.00	0.36	5.00	0.13	1.496	0.014	0.197	0.005
MOR39 x 1.5	39.00	0.37	1.50	0.08	1.535	0.015	0.059	0.003
MOR39 x 2	39.00	0.37	2.00	0.08	1.535	0.015	0.079	0.003
MOR39X2.5	39.00	0.40	2.50	0.09	1.535	0.016	0.098	0.004
MOR39 x 3	39.00	0.37	3.00	0.09	1.535	0.015	0.118	0.004
MOR39X3.5	39.00	0.40	3.50	0.10	1.535	0.016	0.138	0.004
MOR39.5 x 3	39.50	0.37	3.00	0.09	1.555	0.015	0.118	0.004
MOR40 x 1.5	40.00	0.38	1.50	0.08	1.575	0.015	0.059	0.003
MOR40 x 2	40.00	0.38	2.00	0.08	1.575	0.015	0.079	0.003
MOR40X2.5	40.00	0.41	2.50	0.09	1.575	0.016	0.098	0.004
MOR40 x 3	40.00	0.38	3.00	0.09	1.575	0.015	0.118	0.004
MOR40X3.5	40.00	0.41	3.50	0.10	1.575	0.016	0.138	0.004
MOR40 x 4	40.00	0.38	4.00	0.10	1.575	0.015	0.158	0.004
MOR40 x 5	40.00	0.38	5.00	0.13	1.575	0.015	0.197	0.005
MOR41 x 1.5	41.00	0.39	1.50	0.08	1.614	0.015	0.059	0.003
MOR41 x 2	41.00	0.39	2.00	0.08	1.614	0.015	0.079	0.003
MOR41X2.5	41.00	0.42	2.50	0.09	1.614	0.017	0.098	0.004
MOR41 x 3	41.00	0.39	3.00	0.09	1.614	0.015	0.118	0.004
MOR42 x 1.5	42.00	0.40	1.50	0.08	1.654	0.016	0.059	0.003
MOR42 x 2	42.00	0.40	2.00	0.08	1.654	0.016	0.079	0.003
MOR42X2.5	42.00	0.42	2.50	0.09	1.654	0.017	0.098	0.004
MOR42 x 3	42.00	0.40	3.00	0.09	1.654	0.016	0.118	0.004
MOR42X3.5	42.00	0.42	3.50	0.10	1.654	0.017	0.138	0.004
MOR42 x 4	42.00	0.40	4.00	0.10	1.654	0.016	0.158	0.004
MOR42 x 5	42.00	0.40	5.00	0.13	1.654	0.016	0.197	0.005
MOR43 x 1.5	43.00	0.40	1.50	0.08	1.693	0.016	0.059	0.003
MOR43 x 2	43.00	0.40	2.00	0.08	1.693	0.016	0.079	0.003
MOR43X2.5	43.00	0.43	2.50	0.09	1.693	0.017	0.098	0.004
MOR43 x 3	43.00	0.40	3.00	0.09	1.693	0.016	0.118	0.004
MOR43X3.5	43.00	0.43	3.50	0.10	1.693	0.017	0.138	0.004
MOR44 x 2	44.00	0.41	2.00	0.08	1.732	0.016	0.079	0.003
MOR44X2.5	44.00	0.44	2.50	0.09	1.732	0.017	0.098	0.004

Metric Series O-Rings (NBR - 70 Duro)

SIZE	Measurements (mm)				Measurements (Inch)			
	ID	±	CS	±	ID	±	CS	±
MOR44 x 3	44.00	0.41	3.00	0.09	1.732	0.016	0.118	0.004
MOR44 x 4	44.00	0.41	4.00	0.10	1.732	0.016	0.158	0.004
MOR44 x 5	44.00	0.41	5.00	0.13	1.732	0.016	0.197	0.005
MOR44.5 x 3	44.50	0.41	3.00	0.09	1.752	0.016	0.118	0.004
MOR45 x 1.5	45.00	0.42	1.50	0.08	1.772	0.017	0.059	0.003
MOR45 x 2	45.00	0.42	2.00	0.08	1.772	0.017	0.079	0.003
MOR45X2.5	45.00	0.44	2.50	0.09	1.772	0.017	0.098	0.004
MOR45 x 3	45.00	0.42	3.00	0.09	1.772	0.017	0.118	0.004
MOR45X3.5	45.00	0.44	3.50	0.10	1.772	0.017	0.138	0.004
MOR46 x 1.5	46.00	0.43	1.50	0.08	1.811	0.017	0.059	0.003
MOR46 x 2	46.00	0.43	2.00	0.08	1.811	0.017	0.079	0.003
MOR46X2.5	46.00	0.45	2.50	0.09	1.811	0.018	0.098	0.004
MOR46 x 3	46.00	0.43	3.00	0.09	1.811	0.017	0.118	0.004
MOR46X3.5	46.00	0.45	3.50	0.10	1.811	0.018	0.138	0.004
MOR46 x 4	46.00	0.43	4.00	0.10	1.811	0.017	0.158	0.004
MOR46 x 5	46.00	0.43	5.00	0.13	1.811	0.017	0.197	0.005
MOR47 x 1.5	47.00	0.44	1.50	0.08	1.850	0.017	0.059	0.003
MOR47 x 2	47.00	0.44	2.00	0.08	1.850	0.017	0.079	0.003
MOR47X2.5	47.00	0.46	2.50	0.09	1.850	0.014	0.098	0.004
MOR47 x 3	47.00	0.44	3.00	0.09	1.850	0.017	0.118	0.004
MOR47X3.5	47.00	0.46	3.50	0.10	1.850	0.018	0.138	0.004
MOR48 x 1.5	48.00	0.44	1.50	0.08	1.890	0.017	0.059	0.003
MOR48 x 2	48.00	0.44	2.00	0.08	1.890	0.017	0.079	0.003
MOR48X2.5	48.00	0.47	2.50	0.09	1.890	0.019	0.098	0.004
MOR48 x 3	48.00	0.44	3.00	0.09	1.890	0.017	0.118	0.004
MOR48X3.5	48.00	0.47	3.50	0.10	1.890	0.019	0.138	0.004
MOR48 x 4	48.00	0.44	4.00	0.10	1.890	0.017	0.158	0.004
MOR48 x 5	48.00	0.44	5.00	0.13	1.890	0.017	0.197	0.005
MOR49 x 1.5	49.00	0.45	1.50	0.08	1.929	0.018	0.059	0.003
MOR49 x 2	49.00	0.45	2.00	0.08	1.929	0.018	0.079	0.003
MOR49X2.5	49.00	0.47	2.50	0.09	1.929	0.019	0.098	0.004
MOR49 x 3	49.00	0.45	3.00	0.09	1.929	0.018	0.118	0.004
MOR49X3.5	49.00	0.47	3.50	0.10	1.929	0.019	0.138	0.004
MOR49.5 x 3	49.50	0.45	3.00	0.09	1.949	0.018	0.118	0.004
MOR50 x 1.5	50.00	0.46	1.50	0.08	1.969	0.018	0.059	0.003
MOR50 x 2	50.00	0.46	2.00	0.08	1.969	0.018	0.079	0.003
MOR50X2.5	50.00	0.48	2.50	0.09	1.969	0.019	0.098	0.004
MOR50 x 3	50.00	0.46	3.00	0.09	1.969	0.018	0.118	0.004
MOR50X3.5	50.00	0.48	3.50	0.10	1.969	0.019	0.138	0.004
MOR50 x 4	50.00	0.46	4.00	0.10	1.969	0.018	0.158	0.004
MOR50 x 5	50.00	0.46	5.00	0.13	1.969	0.018	0.197	0.005
MOR50 x 6	50.00	0.48	6.00	0.15	1.969	0.019	0.236	0.006
MOR51 x 2	51.00	0.47	2.00	0.08	2.008	0.019	0.079	0.003
MOR51X2.5	51.00	0.49	2.50	0.09	2.008	0.019	0.098	0.004
MOR51 x 3	51.00	0.47	3.00	0.09	2.008	0.019	0.118	0.004
MOR52 x 2	52.00	0.47	2.00	0.08	2.047	0.019	0.079	0.003
MOR52X2.5	52.00	0.05	2.50	0.09	2.047	0.019	0.098	0.004
MOR52 x 3	52.00	0.47	3.00	0.09	2.047	0.019	0.118	0.004
MOR52X3.5	52.00	0.49	3.50	0.10	2.047	0.019	0.138	0.004
MOR52 x 4	52.00	0.47	4.00	0.10	2.047	0.019	0.158	0.004
MOR52 x 5	52.00	0.47	5.00	0.13	2.047	0.019	0.197	0.005
MOR53 x 2	53.00	0.48	2.00	0.08	2.087	0.019	0.079	0.003

SIZE	Measurements (mm)				Measurements (Inch)			
	ID	±	CS	±	ID	±	CS	±
MOR53X2.5	53.00	0.50	2.50	0.09	2.087	0.020	0.098	0.004
MOR53 x 3	53.00	0.48	3.00	0.09	2.087	0.019	0.118	0.004
MOR53X3.5	53.00	0.50	3.50	0.10	2.087	0.020	0.138	0.004
MOR54 x 2	54.00	0.50	2.00	0.08	2.126	0.020	0.079	0.003
MOR54X2.5	54.00	0.51	2.50	0.09	2.126	0.020	0.098	0.004
MOR54 x 3	54.00	0.50	3.00	0.09	2.126	0.020	0.118	0.004
MOR54 x 4	54.00	0.50	4.00	0.10	2.126	0.020	0.158	0.004
MOR54 x 5	54.00	0.50	5.00	0.13	2.126	0.020	0.197	0.005
MOR54.5 x 3	54.50	0.50	3.00	0.09	2.146	0.020	0.118	0.004
MOR55 x 2	55.00	0.50	2.00	0.08	2.165	0.020	0.079	0.003
MOR55X2.5	55.00	0.52	2.50	0.09	2.165	0.020	0.098	0.004
MOR55 x 3	55.00	0.50	3.00	0.09	2.165	0.020	0.118	0.004
MOR55X3.5	55.00	0.52	3.50	0.10	2.165	0.020	0.138	0.004
MOR55 x 6	55.00	0.52	6.00	0.15	2.165	0.020	0.236	0.006
MOR56 x 2	56.00	0.51	2.00	0.08	2.205	0.020	0.079	0.003
MOR56X2.5	56.00	0.52	2.50	0.09	2.205	0.020	0.098	0.004
MOR56 x 3	56.00	0.51	3.00	0.09	2.205	0.020	0.118	0.004
MOR56 x 4	56.00	0.51	4.00	0.10	2.205	0.020	0.158	0.004
MOR57 x 2	57.00	0.52	2.00	0.08	2.244	0.021	0.079	0.003
MOR57X2.5	57.00	0.53	2.50	0.09	2.244	0.021	0.098	0.004
MOR57 x 3	57.00	0.52	3.00	0.09	2.244	0.021	0.118	0.004
MOR57X3.5	57.00	0.53	3.50	0.10	2.244	0.021	0.138	0.004
MOR58 x 2	58.00	0.52	2.00	0.08	2.284	0.021	0.079	0.003
MOR58X2.5	58.00	0.54	2.50	0.09	2.283	0.021	0.098	0.004
MOR58 x 3	58.00	0.52	3.00	0.09	2.284	0.021	0.118	0.004
MOR58X3.5	58.00	0.54	3.50	0.10	2.283	0.021	0.138	0.004
MOR58 x 4	58.00	0.52	4.00	0.10	2.284	0.021	0.158	0.004
MOR58 x 5	58.00	0.52	5.00	0.13	2.284	0.021	0.197	0.005
MOR59 x 2	59.00	0.54	2.00	0.08	2.323	0.021	0.079	0.003
MOR59 x 3	59.00	0.54	3.00	0.09	2.323	0.021	0.118	0.004
MOR59.5 x 3	59.50	0.54	3.00	0.09	2.343	0.021	0.118	0.004
MOR60 x 2	60.00	0.54	2.00	0.08	2.362	0.021	0.079	0.003
MOR60X2.5	60.00	0.55	2.50	0.09	2.362	0.022	0.098	0.004
MOR60 x 3	60.00	0.54	3.00	0.09	2.362	0.021	0.118	0.004
MOR60X3.5	60.00	0.55	3.50	0.10	2.362	0.022	0.138	0.004
MOR60 x 4	60.00	0.54	4.00	0.10	2.362	0.021	0.158	0.004
MOR60 x 5	60.00	0.54	5.00	0.13	2.362	0.021	0.197	0.005
MOR60 x 6	60.00	0.55	6.00	0.15	2.362	0.022	0.236	0.006
MOR62 x 2	62.00	0.55	2.00	0.08	2.441	0.022	0.079	0.003
MOR62X2.5	62.00	0.56	2.50	0.09	2.441	0.022	0.098	0.004
MOR62 x 3	62.00	0.55	3.00	0.09	2.441	0.022	0.118	0.004
MOR62X3.5	62.00	0.56	3.50	0.10	2.441	0.022	0.138	0.004
MOR62 x 4	62.00	0.55	4.00	0.10	2.441	0.022	0.158	0.004
MOR62 x 5	62.00	0.55	5.00	0.13	2.441	0.022	0.197	0.005
MOR63X2.5	63.00	0.57	2.50	0.09	2.480	0.022	0.098	0.004
MOR64 x 2	64.00	0.58	2.00	0.08	2.520	0.023	0.079	0.003
MOR64X2.5	64.00	0.58	2.50	0.09	2.520	0.023	0.098	0.004
MOR64 x 3	64.00	0.58	3.00	0.09	2.520	0.023	0.118	0.004
MOR64X3.5	64.00	0.58	3.50	0.10	2.520	0.025	0.138	0.004
MOR64 x 4	64.00	0.58	4.00	0.10	2.520	0.023	0.158	0.004
MOR64 x 5	64.00	0.58	5.00	0.13	2.520	0.023	0.197	0.005
MOR65X2.5	65.00	0.58	2.50	0.09	2.559	0.023	0.098	0.004

Metric Series O-Rings (NBR - 70 Duro)

SIZE	Measurements (mm)				Measurements (Inch)			
	ID	±	CS	±	ID	±	CS	±
MOR65X3.5	65.00	0.58	3.50	0.10	2.599	0.023	0.138	0.004
MOR65 x 6	65.00	0.58	6.00	0.15	2.559	0.023	0.236	0.006
MOR66 x 2	66.00	0.59	2.00	0.08	2.598	0.023	0.079	0.003
MOR66X2.5	66.00	0.59	2.50	0.09	2.598	0.023	0.098	0.004
MOR66 x 3	66.00	0.59	3.00	0.09	2.598	0.023	0.118	0.004
MOR66 x 4	66.00	0.59	4.00	0.10	2.598	0.023	0.158	0.004
MOR66 x 5	66.00	0.59	5.00	0.13	2.598	0.023	0.197	0.005
MOR67X2.5	67.00	0.60	2.50	0.09	2.638	0.024	0.098	0.004
MOR67X3.5	67.00	0.60	3.50	0.10	2.638	0.024	0.138	0.004
MOR68 x 2	68.00	0.61	2.00	0.08	2.677	0.024	0.079	0.003
MOR68X2.5	68.00	0.61	2.50	0.09	2.677	0.024	0.098	0.004
MOR68 x 3	68.00	0.61	3.00	0.09	2.677	0.024	0.118	0.004
MOR68X3.5	68.00	0.61	3.50	0.10	2.677	0.024	0.138	0.004
MOR68 x 4	68.00	0.61	4.00	0.10	2.677	0.024	0.158	0.004
MOR68 x 5	68.00	0.61	5.00	0.13	2.677	0.024	0.197	0.005
MOR69X2.5	69.00	0.61	2.50	0.09	2.717	0.024	0.098	0.004
MOR70 x 2	70.00	0.62	2.00	0.08	2.756	0.024	0.079	0.003
MOR70X2.5	70.00	0.62	2.50	0.09	2.756	0.024	0.098	0.004
MOR70 x 3	70.00	0.62	3.00	0.09	2.756	0.024	0.118	0.004
MOR70X3.5	70.00	0.62	3.50	0.10	2.756	0.024	0.138	0.004
MOR70 x 4	70.00	0.62	4.00	0.10	2.756	0.024	0.158	0.004
MOR70 x 5	70.00	0.62	5.00	0.13	2.756	0.024	0.197	0.005
MOR70 x 6	70.00	0.62	6.00	0.15	2.756	0.024	0.236	0.006
MOR71X2.5	71.00	0.63	2.50	0.09	2.795	0.025	0.098	0.004
MOR71X3.5	71.00	0.63	3.50	0.10	2.795	0.025	0.138	0.004
MOR72 x 2	72.00	0.63	2.00	0.08	2.835	0.025	0.079	0.003
MOR72X2.5	72.00	0.63	2.50	0.09	2.835	0.025	0.098	0.004
MOR72 x 3	72.00	0.63	3.00	0.09	2.835	0.025	0.118	0.004
MOR73X2.5	73.00	0.64	2.50	0.09	2.874	0.025	0.098	0.004
MOR73X3.5	73.00	0.64	3.50	0.10	2.874	0.025	0.138	0.004
MOR72 x 4	72.00	0.63	4.00	0.10	2.835	0.025	0.158	0.004
MOR72 x 5	72.00	0.63	5.00	0.13	2.835	0.025	0.197	0.005
MOR74 x 2	74.00	0.65	2.00	0.08	2.913	0.026	0.079	0.003
MOR74 x 3	74.00	0.65	3.00	0.09	2.913	0.026	0.118	0.004
MOR74 x 4	74.00	0.65	4.00	0.10	2.913	0.026	0.158	0.004
MOR74 x 5	74.00	0.65	5.00	0.13	2.913	0.026	0.197	0.005
MOR75X2.5	75.00	0.65	2.50	0.09	2.953	0.026	0.098	0.004
MOR75X3.5	75.00	0.65	3.50	0.10	2.953	0.026	0.138	0.004
MOR75 x 6	75.00	0.65	6.00	0.15	2.953	0.026	0.236	0.006
MOR76 x 2	76.00	0.66	2.00	0.08	2.992	0.026	0.079	0.003
MOR76X2.5	76.00	0.66	2.50	0.09	2.992	0.026	0.098	0.004
MOR76 x 3	76.00	0.66	3.00	0.09	2.992	0.026	0.118	0.004
MOR76X3.5	76.00	0.66	3.50	0.10	2.992	0.026	0.138	0.004
MOR76 x 4	76.00	0.66	4.00	0.10	2.992	0.026	0.158	0.004
MOR76 x 5	76.00	0.66	5.00	0.13	2.992	0.026	0.197	0.005
MOR77X3.5	77.00	0.67	3.50	0.10	3.031	0.026	0.138	0.004
MOR78 x 2	78.00	0.67	2.00	0.08	3.071	0.026	0.079	0.003
MOR78X2.5	78.00	0.67	2.50	0.09	3.071	0.026	0.098	0.004
MOR78 x 3	78.00	0.67	3.00	0.09	3.071	0.026	0.118	0.004
MOR78X3.5	78.00	0.67	3.50	0.10	3.071	0.026	0.138	0.004
MOR78 x 4	78.00	0.67	4.00	0.10	3.071	0.026	0.158	0.004
MOR78 x 5	78.00	0.67	5.00	0.13	3.071	0.026	0.197	0.005

SIZE	Measurements (mm)				Measurements (Inch)			
	ID	±	CS	±	ID	±	CS	±
MOR79X2.5	79.00	0.68	2.50	0.09	3.110	0.027	0.098	0.004
MOR80 x 2	80.00	0.69	2.00	0.08	3.150	0.027	0.079	0.003
MOR80X2.5	80.00	0.69	2.50	0.09	3.150	0.027	0.098	0.004
MOR80 x 3	80.00	0.69	3.00	0.09	3.150	0.027	0.118	0.004
MOR80X3.5	80.00	0.69	3.50	0.10	3.150	0.027	0.138	0.004
MOR80 x 4	80.00	0.69	4.00	0.10	3.150	0.027	0.158	0.004
MOR80 x 5	80.00	0.69	5.00	0.13	3.150	0.027	0.197	0.005
MOR80 x 6	80.00	0.69	6.00	0.15	3.150	0.027	0.236	0.006
MOR81X2.5	81.00	0.70	2.50	0.09	3.189	0.028	0.098	0.004
MOR81X3.5	81.00	0.70	3.50	0.10	3.189	0.028	0.138	0.004
MOR82 x 2	82.00	0.70	2.00	0.08	3.228	0.028	0.079	0.003
MOR82X2.5	82.00	0.70	2.50	0.09	3.228	0.028	0.098	0.004
MOR82 x 3	82.00	0.70	3.00	0.09	3.228	0.028	0.118	0.004
MOR82 x 4	82.00	0.70	4.00	0.10	3.228	0.028	0.158	0.004
MOR82 x 5	82.00	0.70	5.00	0.13	3.228	0.028	0.197	0.005
MOR83X2.5	83.00	0.71	2.50	0.09	3.268	0.028	0.098	0.004
MOR84 x 2	84.00	0.72	2.00	0.08	3.307	0.028	0.079	0.003
MOR84X2.5	84.00	0.72	2.50	0.09	3.307	0.028	0.098	0.004
MOR84 x 3	84.00	0.72	3.00	0.09	3.307	0.028	0.118	0.004
MOR84X3.5	84.00	0.72	3.50	0.10	3.307	0.028	0.138	0.004
MOR84 x 4	84.00	0.72	4.00	0.10	3.307	0.028	0.158	0.004
MOR84 x 5	84.00	0.72	5.00	0.13	3.307	0.028	0.197	0.005
MOR85X2.5	85.00	0.72	2.50	0.09	3.346	0.028	0.098	0.004
MOR85X3.5	85.00	0.72	3.50	0.10	3.346	0.028	0.138	0.004
MOR85 x 6	85.00	0.72	6.00	0.15	3.347	0.028	0.236	0.006
MOR86 x 2	86.00	0.73	2.00	0.08	3.386	0.029	0.079	0.003
MOR86 x 3	86.00	0.73	3.00	0.09	3.386	0.029	0.118	0.004
MOR86 x 4	86.00	0.73	4.00	0.10	3.386	0.029	0.158	0.004
MOR86 x 5	86.00	0.73	5.00	0.13	3.386	0.029	0.197	0.005
MOR87X3.5	87.00	0.74	3.50	0.10	3.425	0.029	0.138	0.004
MOR88 x 3	88.00	0.74	3.00	0.09	3.465	0.029	0.118	0.004
MOR88 x 4	88.00	0.74	4.00	0.10	3.465	0.029	0.158	0.004
MOR88 x 5	88.00	0.74	5.00	0.13	3.465	0.029	0.197	0.005
MOR9.5 x 2	9.50	0.17	2.00	0.08	0.374	0.007	0.079	0.003
MOR90 x 2	90.00	0.76	2.00	0.08	3.543	0.030	0.079	0.003
MOR90X2.5	90.00	0.76	2.50	0.09	3.543	0.030	0.098	0.004
MOR90 x 3	90.00	0.76	3.00	0.09	3.543	0.030	0.118	0.004
MOR90X3.5	90.00	0.76	3.50	0.10	3.543	0.030	0.138	0.004
MOR90 x 4	90.00	0.76	4.00	0.10	3.543	0.030	0.158	0.004
MOR90 x 5	90.00	0.76	5.00	0.13	3.543	0.030	0.197	0.005
MOR90 x 6	90.00	0.76	6.00	0.15	3.543	0.030	0.236	0.006
MOR92 x 2	92.00	0.77	2.00	0.08	3.622	0.030	0.079	0.003
MOR92 x 3	92.00	0.77	3.00	0.09	3.622	0.030	0.118	0.004
MOR92 x 4	92.00	0.77	4.00	0.10	3.622	0.030	0.158	0.004
MOR92 x 5	92.00	0.77	5.00	0.13	3.622	0.030	0.197	0.005
MOR93X3.5	93.00	0.78	3.50	0.10	3.661	0.031	0.138	0.004
MOR94 x 2	94.00	0.78	2.00	0.08	3.701	0.031	0.079	0.003
MOR94 x 4	94.00	0.78	4.00	0.10	3.701	0.031	0.158	0.004
MOR94 x 5	94.00	0.78	5.00	0.13	3.701	0.031	0.197	0.005
MOR95X2.5	95.00	0.79	2.50	0.09	3.740	0.031	0.098	0.004
MOR95 x 3	95.00	0.79	3.00	0.09	3.740	0.031	0.118	0.004
MOR95 x 6	95.00	0.79	6.00	0.15	3.740	0.031	0.236	0.006

Metric Series O-Rings (NBR - 70 Duro)

SIZE	Measurements (mm)				Measurements (Inch)			
	ID	±	CS	±	ID	±	CS	±
MOR96 x 2	96.00	0.80	2.00	0.08	3.780	0.032	0.079	0.003
MOR96X2.5	96.00	0.80	2.50	0.09	3.780	0.031	0.098	0.004
MOR96 x 4	96.00	0.80	4.00	0.10	3.780	0.032	0.158	0.004
MOR96 x 5	96.00	0.80	5.00	0.13	3.780	0.032	0.197	0.005
MOR97X2.5	97.00	0.80	2.50	0.09	3.819	0.031	0.098	0.004
MOR98 x 2	98.00	0.81	2.00	0.08	3.858	0.032	0.079	0.003
MOR98X2.5	98.00	0.81	2.50	0.09	3.858	0.032	0.098	0.004
MOR98 x 3	98.00	0.81	3.00	0.09	3.858	0.032	0.118	0.004
MOR98X3.5	98.00	0.81	3.50	0.10	3.858	0.032	0.138	0.004
MOR98 x 4	98.00	0.81	4.00	0.10	3.858	0.032	0.158	0.004
MOR98 x 5	98.00	0.81	5.00	0.13	3.858	0.032	0.197	0.005
MOR100 x 2	100.00	0.82	2.00	0.08	3.937	0.032	0.079	0.003
MOR100X2.5	100.00	0.82	2.50	0.09	3.937	0.032	0.098	0.004
MOR100 x 3	100.00	0.82	3.00	0.09	3.937	0.032	0.118	0.004
MOR100X3.5	100.00	0.82	3.50	0.10	3.937	0.032	0.138	0.004
MOR100 x 4	100.00	0.82	4.00	0.10	3.937	0.032	0.158	0.004
MOR100 x 5	100.00	0.82	5.00	0.13	3.937	0.032	0.197	0.005
MOR100 x 6	100.00	0.82	6.00	0.15	3.937	0.033	0.236	0.006
MOR102X2.5	102.00	0.84	2.50	0.09	4.016	0.033	0.098	0.004
MOR105X2.5	105.00	0.86	2.50	0.09	4.134	0.034	0.098	0.004
MOR105 x 3	105.00	0.86	3.00	0.09	4.134	0.034	0.118	0.004
MOR105X3.5	105.00	0.86	3.50	0.10	4.134	0.034	0.138	0.004
MOR105 x 4	105.00	0.86	4.00	0.10	4.134	0.034	0.158	0.004
MOR105 x 5	105.00	0.86	5.00	0.13	4.134	0.034	0.197	0.005
MOR105 x 6	105.00	0.86	6.00	0.15	4.134	0.034	0.236	0.006
MOR106X2.5	106.00	0.87	2.50	0.09	4.173	0.034	0.098	0.004
MOR107X2.5	107.00	0.87	2.50	0.09	4.213	0.034	0.098	0.004
MOR110X2.5	110.00	0.89	2.50	0.09	4.331	0.035	0.098	0.004
MOR110 x 3	110.00	0.89	3.00	0.09	4.331	0.035	0.118	0.004
MOR110X3.5	110.00	0.89	3.50	0.10	4.331	0.035	0.138	0.004
MOR110 x 4	110.00	0.89	4.00	0.10	4.331	0.035	0.158	0.004
MOR110 x 5	110.00	0.89	5.00	0.13	4.331	0.035	0.197	0.005
MOR110 x 6	110.00	0.89	6.00	0.15	4.331	0.035	0.236	0.006
MOR111X2.5	111.00	0.90	2.50	0.09	4.370	0.035	0.098	0.004
MOR112X2.5	112.00	0.91	2.50	0.09	4.409	0.036	0.098	0.004
MOR115X2.5	115.00	0.93	2.50	0.09	4.528	0.037	0.098	0.004
MOR115 x 3	115.00	0.93	3.00	0.09	4.528	0.037	0.118	0.004
MOR115 x 4	115.00	0.93	4.00	0.10	4.528	0.037	0.158	0.004
MOR115 x 5	115.00	0.93	5.00	0.13	4.528	0.037	0.197	0.005
MOR115 x 6	115.00	0.93	6.00	0.15	4.528	0.037	0.236	0.006
MOR117X2.5	117.00	0.94	2.50	0.09	4.606	0.037	0.098	0.004
MOR120X2.5	120.00	0.96	2.50	0.09	4.724	0.038	0.098	0.004
MOR120 x 3	120.00	0.96	3.00	0.09	4.724	0.038	0.118	0.004
MOR120X3.5	120.00	0.96	3.50	0.10	4.724	0.038	0.138	0.004
MOR120 x 4	120.00	0.96	4.00	0.10	4.724	0.038	0.158	0.004
MOR120 x 5	120.00	0.96	5.00	0.13	4.724	0.038	0.197	0.005
MOR120 x 6	120.00	0.96	6.00	0.15	4.724	0.038	0.236	0.006
MOR122X2.5	122.00	0.97	2.50	0.09	4.803	0.038	0.098	0.004
MOR125X2.5	125.00	0.99	2.50	0.09	4.921	0.039	0.098	0.004
MOR125 x 3	125.00	0.99	3.00	0.09	4.921	0.039	0.118	0.004
MOR125 x 4	125.00	0.99	4.00	0.10	4.921	0.039	0.158	0.004
MOR125 x 5	125.00	0.99	5.00	0.13	4.921	0.039	0.197	0.005

SIZE	Measurements (mm)				Measurements (Inch)			
	ID	±	CS	±	ID	±	CS	±
MOR125 x 6	125.00	0.99	6.00	0.15	4.921	0.039	0.236	0.006
MOR127X2.5	127.00	1.01	2.50	0.09	5.000	0.040	0.980	0.004
MOR130X2.5	130.00	1.03	2.50	0.09	5.118	0.041	0.098	0.004
MOR130 x 3	130.00	1.03	3.00	0.09	5.118	0.041	0.118	0.004
MOR130 x 4	130.00	1.03	4.00	0.10	5.118	0.041	0.158	0.004
MOR130 x 5	130.00	1.03	5.00	0.13	5.118	0.041	0.197	0.005
MOR130 x 6	130.00	1.03	6.00	0.15	5.118	0.040	0.236	0.006
MOR135 x 3	135.00	1.06	3.00	0.09	5.315	0.042	0.118	0.004
MOR135X2.5	135.00	1.06	2.50	0.09	5.315	0.042	0.098	0.004
MOR135 x 4	135.00	1.06	4.00	0.10	5.315	0.042	0.158	0.004
MOR135 x 5	135.00	1.06	5.00	0.13	5.315	0.042	0.197	0.005
MOR135 x 6	135.00	1.06	6.00	0.15	5.315	0.042	0.236	0.006
MOR140 x 3	140.00	1.09	3.00	0.09	5.512	0.043	0.118	0.004
MOR140 x 4	140.00	1.09	4.00	0.10	5.512	0.043	0.158	0.004
MOR140 x 5	140.00	1.09	5.00	0.13	5.512	0.043	0.197	0.005
MOR140 x 6	140.00	1.09	6.00	0.15	5.512	0.043	0.236	0.006
MOR140X2.5	140.00	1.09	2.50	0.09	5.512	0.043	0.098	0.004
MOR145X2.5	145.00	1.13	2.50	0.09	5.709	0.044	0.098	0.004
MOR145 x 3	145.00	1.13	3.00	0.09	5.709	0.045	0.118	0.004
MOR145X3.5	145.00	1.13	3.50	0.10	5.709	0.044	0.138	0.004
MOR145 x 4	145.00	1.13	4.00	0.10	5.709	0.045	0.158	0.004
MOR150X2.5	150.00	1.16	2.50	0.09	5.906	0.046	0.098	0.004
MOR150X3.5	150.00	1.16	3.50	0.10	5.906	0.046	0.138	0.004

Metric Series O-Rings (NBR - 70 Duro)

SIZE	Measurements (mm)				Measurements (Inch)			
	ID	±	CS	±	ID	±	CS	±
MOR145 x 5	145	1.13	5	0.13	5.7087	0.0445	0.1969	0.0051
MOR145 x 6	145	1.13	6	0.15	5.7087	0.0444	0.2362	0.0059
MOR150 x 3	150	1.16	3	0.09	5.9055	0.0457	0.1181	0.0035
MOR150 x 4	150	1.16	4	0.1	5.9055	0.0457	0.1575	0.0039
MOR150 x 5	150	1.16	5	0.13	5.9055	0.0457	0.1969	0.0051
MOR150 x 6	150	1.16	6	0.15	5.9055	0.0457	0.2362	0.0059



BS Series Viton O-Rings (75 Viton)

SIZE	Nominal (Reference)			Measurement (Inch)				Measurement (mm)			
	ID	OD	CS	ID	±	CS	±	ID	±	CS	±
BS001V	1/32	3/32	1/32	0.029	0.004	0.04	0.003	0.74	0.1	1.02	0.08
BS002V	3/64	9/64	3/64	0.042	0.004	0.05	0.003	1.07	0.1	1.27	0.08
BS003V	1/16	3/16	1/16	0.056	0.004	0.06	0.003	1.42	0.1	1.52	0.08
BS004V	5/64	13/64	1/16	0.07	0.005	0.07	0.003	1.78	0.13	1.78	0.08
BS005V	3/32	7/32	1/16	0.101	0.005	0.07	0.003	2.57	0.13	1.78	0.08
BS006V	1/8	1/4	1/16	0.114	0.005	0.07	0.003	2.9	0.13	1.78	0.08
BS007V	5/32	9/32	1/16	0.145	0.005	0.07	0.003	3.68	0.13	1.78	0.08
BS008V	3/16	5/16	1/16	0.176	0.005	0.07	0.003	4.47	0.13	1.78	0.08
BS009V	7/32	11/32	1/16	0.208	0.005	0.07	0.003	5.28	0.13	1.78	0.08
BS010V	1/4	3/8	1/16	0.239	0.005	0.07	0.003	6.07	0.13	1.78	0.08
BS011V	5/16	7/16	1/16	0.301	0.005	0.07	0.003	7.65	0.13	1.78	0.08
BS012V	3/8	1/2	1/16	0.364	0.005	0.07	0.003	9.25	0.13	1.78	0.08
BS013V	7/16	9/16	1/16	0.426	0.005	0.07	0.003	10.82	0.13	1.78	0.08
BS014V	1/2	5/8	1/16	0.489	0.005	0.07	0.003	12.42	0.13	1.78	0.08
BS015V	9/16	11/16	1/16	0.551	0.007	0.07	0.003	14	0.18	1.78	0.08
BS016V	5/8	3/4	1/16	0.614	0.009	0.07	0.003	15.6	0.23	1.78	0.08
BS017V	11/16	13/16	1/16	0.676	0.009	0.07	0.003	17.17	0.23	1.78	0.08
BS018V	3/4	7/8	1/16	0.739	0.009	0.07	0.003	18.77	0.23	1.78	0.08
BS019V	13/16	15/16	1/16	0.801	0.009	0.07	0.003	20.35	0.23	1.78	0.08
BS020V	7/8	1	1/16	0.864	0.009	0.07	0.003	21.95	0.23	1.78	0.08
BS021V	15/16	1 1/16	1/16	0.926	0.009	0.07	0.003	23.52	0.23	1.78	0.08
BS022V	1	1/8	1/16	0.989	0.01	0.07	0.003	25.12	0.25	1.78	0.08
BS023V	1 1/16	1 3/16	1/16	1.051	0.01	0.07	0.003	26.7	0.25	1.78	0.08
BS024V	1 1/8	1 1/4	1/16	1.114	0.01	0.07	0.003	28.3	0.25	1.78	0.08
BS025V	1 3/16	1 5/16	1/16	1.176	0.011	0.07	0.003	29.87	0.28	1.78	0.08
BS026V	1 1/4	1 3/8	1/16	1.239	0.011	0.07	0.003	31.47	0.28	1.78	0.08
BS027V	1 5/16	1 7/16	1/16	1.301	0.011	0.07	0.003	33.05	0.28	1.78	0.08
BS028V	1 3/8	1 1/2	1/16	1.364	0.013	0.07	0.003	34.65	0.33	1.78	0.08
BS029V	1 1/2	1 5/8	1/16	1.489	0.013	0.07	0.003	37.82	0.33	1.78	0.08
BS030V	1 5/8	1 3/4	1/16	1.614	0.013	0.07	0.003	41	0.33	1.78	0.08
BS031V	1 3/4	1 7/8	1/16	1.739	0.015	0.07	0.003	44.17	0.38	1.78	0.08
BS032V	1 7/8	2	1/16	1.864	0.015	0.07	0.003	47.35	0.38	1.78	0.08
BS033V	2	2 1/8	1/16	1.989	0.018	0.07	0.003	50.52	0.46	1.78	0.08
BS034V	2 1/8	2 1/4	1/16	2.114	0.018	0.07	0.003	53.7	0.46	1.78	0.08
BS035V	2 1/4	2 3/8	1/16	2.239	0.018	0.07	0.003	56.87	0.46	1.78	0.08
BS036V	2 3/8	2 1/2	1/16	2.364	0.018	0.07	0.003	60.05	0.46	1.78	0.08
BS037V	2 1/2	2 5/8	1/16	2.489	0.018	0.07	0.003	63.22	0.46	1.78	0.08
BS038V	2 5/8	2 3/4	1/16	2.614	0.02	0.07	0.003	66.4	0.51	1.78	0.08
BS039V	2 3/4	2 7/8	1/16	2.739	0.02	0.07	0.003	69.57	0.51	1.78	0.08
BS040V	2 7/8	3	1/16	2.864	0.02	0.07	0.003	72.75	0.51	1.78	0.08
BS041V	3	3 1/8	1/16	2.989	0.024	0.07	0.003	75.92	0.61	1.78	0.08
BS042V	3 1/4	3 3/8	1/16	3.239	0.024	0.07	0.003	82.27	0.61	1.78	0.08
BS043V	3 1/2	3 5/8	1/16	3.489	0.024	0.07	0.003	88.62	0.61	1.78	0.08
BS044V	3 3/4	3 7/8	1/16	3.739	0.027	0.07	0.003	94.97	0.69	1.78	0.08
BS045V	4	4 1/8	1/16	3.989	0.027	0.07	0.003	101.32	0.69	1.78	0.08
BS046V	4 1/4	4 3/8	1/16	4.239	0.03	0.07	0.003	107.67	0.76	1.78	0.08
BS047V	4 1/2	4 3/8	1/16	4.489	0.03	0.07	0.003	114.02	0.76	1.78	0.08
BS048V	4 3/4	4 7/8	1/16	4.739	0.03	0.07	0.003	120.37	0.76	1.78	0.08
BS049V	5	5 1/8	1/16	4.989	0.037	0.07	0.003	126.72	0.94	1.78	0.08

O-Rings

BS Series Viton O-Rings (75 Viton)

SIZE	Nominal (Reference)			Measurement (Inch)				Measurement (mm)			
	ID	OD	CS	ID	±	CS	±	ID	±	CS	±
BS050V	5 1/4	5 3/8	1/16	5.239	0.037	0.07	0.003	133.07	0.94	1.78	0.08
BS102V	1/16	1/4	3/32	0.049	0.005	0.103	0.003	1.24	0.13	2.62	0.08
BS103V	3/32	9/32	3/32	0.081	0.005	0.103	0.003	2.06	0.13	2.62	0.08
BS104V	1/8	5/16	3/32	0.112	0.005	0.103	0.003	2.84	0.13	2.62	0.08
BS105V	5/32	11/32	3/32	0.143	0.005	0.103	0.003	3.63	0.13	2.62	0.08
BS106V	3/16	3/8	3/32	0.174	0.005	0.103	0.003	4.42	0.13	2.62	0.08
BS107V	7/32	13/32	3/32	0.206	0.005	0.103	0.003	5.23	0.13	2.62	0.08
BS108V	1/4	7/16	3/32	0.237	0.005	0.103	0.003	6.02	0.13	2.62	0.08
BS109V	5/16	1/2	3/32	0.299	0.005	0.103	0.003	7.59	0.13	2.62	0.08
BS110V	3/8	9/16	3/32	0.362	0.005	0.103	0.003	9.19	0.13	2.62	0.08
BS111V	7/16	5/8	3/32	0.424	0.005	0.103	0.003	10.77	0.13	2.62	0.08
BS112V	1/2	11/16	3/32	0.487	0.005	0.103	0.003	12.37	0.13	2.62	0.08
BS113V	9/16	3/4	3/32	0.549	0.007	0.103	0.003	13.94	0.18	2.62	0.08
BS114V	5/8	13/16	3/32	0.612	0.009	0.103	0.003	15.54	0.23	2.62	0.08
BS115V	11/16	7/8	3/32	0.674	0.009	0.103	0.003	17.12	0.23	2.62	0.08
BS116V	3/4	15/16	3/32	0.737	0.009	0.103	0.003	18.72	0.23	2.62	0.08
BS117V	13/16	1	3/32	0.799	0.01	0.103	0.003	20.29	0.25	2.62	0.08
BS118V	7/8	1 1/16	3/32	0.862	0.01	0.103	0.003	21.89	0.25	2.62	0.08
BS119V	15/16	1 1/8	3/32	0.924	0.01	0.103	0.003	23.47	0.25	2.62	0.08
BS120V	1	1 3/16	3/32	0.987	0.01	0.103	0.003	25.07	0.25	2.62	0.08
BS121V	1 1/16	1 1/4	3/32	1.049	0.01	0.103	0.003	26.64	0.25	2.62	0.08
BS122V	1 1/8	1 5/16	3/32	1.112	0.01	0.103	0.003	28.24	0.25	2.62	0.08
BS123V	1 3/16	1 3/8	3/32	1.174	0.012	0.103	0.003	29.82	0.3	2.62	0.08
BS124V	1 1/4	1 7/16	3/32	1.237	0.012	0.103	0.003	31.42	0.3	2.62	0.08
BS125V	1 5/16	1 1/2	3/32	1.299	0.012	0.103	0.003	32.99	0.3	2.62	0.08
BS126V	1 3/8	1 9/16	3/32	1.362	0.012	0.103	0.003	34.59	0.3	2.62	0.08
BS127V	1 7/16	1 5/8	3/32	1.424	0.012	0.103	0.003	36.17	0.3	2.62	0.08
BS128V	1 1/2	1 11/16	3/32	1.487	0.012	0.103	0.003	37.77	0.3	2.62	0.08
BS129V	1 9/16	1 3/4	3/32	1.549	0.015	0.103	0.003	39.34	0.38	2.62	0.08
BS130V	1 5/8	1 13/16	3/32	1.612	0.015	0.103	0.003	40.94	0.38	2.62	0.08
BS131V	1 11/16	1 7/8	3/32	1.674	0.015	0.103	0.003	42.52	0.38	2.62	0.08
BS132V	1 3/4	1 15/16	3/32	1.737	0.015	0.103	0.003	44.12	0.38	2.62	0.08
BS133V	1 13/16	2	3/32	1.799	0.015	0.103	0.003	45.69	0.38	2.62	0.08
BS134V	1 7/8	2 1/16	3/32	1.862	0.015	0.103	0.003	47.29	0.38	2.62	0.08
BS135V	1 15/16	2 1/8	3/32	1.925	0.017	0.103	0.003	48.9	0.43	2.62	0.08
BS136V	2	2 3/16	3/32	1.987	0.017	0.103	0.003	50.47	0.43	2.62	0.08
BS137V	2 1/16	2 1/4	3/32	2.05	0.017	0.103	0.003	52.07	0.43	2.62	0.08
BS138V	2 1/8	2 5/16	3/32	2.112	0.017	0.103	0.003	53.64	0.43	2.62	0.08
BS139V	2 3/16	2 3/8	3/32	2.175	0.017	0.103	0.003	55.25	0.43	2.62	0.08
BS140V	2 1/4	2 7/16	3/32	2.237	0.017	0.103	0.003	56.82	0.43	2.62	0.08
BS141V	2 5/16	2 1/2	3/32	2.3	0.02	0.103	0.003	58.42	0.51	2.62	0.08
BS142V	2 3/8	2 9/16	3/32	2.362	0.02	0.103	0.003	59.99	0.51	2.62	0.08
BS143V	2 7/16	2 5/8	3/32	2.425	0.02	0.103	0.003	61.6	0.51	2.62	0.08
BS144V	2 1/2	2 11/16	3/32	2.487	0.02	0.103	0.003	63.17	0.51	2.62	0.08
BS145V	2 9/16	2 3/4	3/32	2.55	0.02	0.103	0.003	64.77	0.51	2.62	0.08
BS146V	2 5/8	2 13/16	3/32	2.612	0.02	0.103	0.003	66.34	0.51	2.62	0.08
BS147V	2 11/16	2 7/8	3/32	2.675	0.022	0.103	0.003	67.95	0.56	2.62	0.08
BS148V	2 3/4	2 15/16	3/32	2.737	0.022	0.103	0.003	69.52	0.56	2.62	0.08
BS149V	2 13/16	3	3/32	2.8	0.022	0.103	0.003	71.12	0.56	2.62	0.08

BS Series Viton O-Rings (75 Viton)

SIZE	Nominal (Reference)			Measurement (Inch)				Measurement (mm)			
	ID	OD	CS	ID	±	CS	±	ID	±	CS	±
BS150V	2 7/8	3 1/16	3/32	2.862	0.022	0.103	0.003	72.69	0.56	2.62	0.08
BS151V	3	3 3/16	3/32	2.987	0.024	0.103	0.003	75.87	0.61	2.62	0.08
BS152V	3 1/4	3 7/16	3/32	3.237	0.024	0.103	0.003	82.22	0.61	2.62	0.08
BS153V	3 1/2	3 11/16	3/32	3.487	0.024	0.103	0.003	88.57	0.61	2.62	0.08
BS154V	3 3/4	3 15/16	3/32	3.737	0.028	0.103	0.003	94.92	0.71	2.62	0.08
BS155V	4	4 3/16	3/32	3.987	0.028	0.103	0.003	101.27	0.71	2.62	0.08
BS156V	4 1/4	4 7/16	3/32	4.237	0.03	0.103	0.003	107.62	0.76	2.62	0.08
BS157V	4 1/2	4 11/16	3/32	4.487	0.03	0.103	0.003	113.97	0.76	2.62	0.08
BS158V	4 3/4	4 15/16	3/32	4.737	0.03	0.103	0.003	120.32	0.76	2.62	0.08
BS159V	5	5 3/16	3/32	4.987	0.035	0.103	0.003	126.67	0.89	2.62	0.08
BS160V	5 1/4	5 7/16	3/32	5.237	0.035	0.103	0.003	133.02	0.89	2.62	0.08
BS161V	5 1/2	5 11/16	3/32	5.487	0.035	0.103	0.003	139.37	0.89	2.62	0.08
BS162V	5 3/4	5 15/16	3/32	5.737	0.035	0.103	0.003	145.72	0.89	2.62	0.08
BS163V	6	6 3/16	3/32	5.987	0.035	0.103	0.003	152.07	0.89	2.62	0.08
BS164V	6 1/4	6 7/16	3/32	6.237	0.04	0.103	0.003	158.42	1.02	2.62	0.08
BS165V	6 1/2	6 11/16	3/32	6.487	0.04	0.103	0.003	164.77	1.02	2.62	0.08
BS166V	6 3/4	6 15/16	3/32	6.737	0.04	0.103	0.003	171.12	1.02	2.62	0.08
BS167V	7	7 3/16	3/32	6.987	0.04	0.103	0.003	177.47	1.02	2.62	0.08
BS168V	7 1/4	7 7/16	3/32	7.237	0.045	0.103	0.003	183.82	1.14	2.62	0.08
BS169V	7 1/2	7 11/16	3/32	7.487	0.045	0.103	0.003	190.17	1.14	2.62	0.08
BS170V	7 3/4	7 15/16	3/32	7.737	0.045	0.103	0.003	196.52	1.14	2.62	0.08
BS171V	8	8 3/16	3/32	7.987	0.045	0.103	0.003	202.87	1.14	2.62	0.08
BS172V	8 1/4	8 7/16	3/32	8.237	0.05	0.103	0.003	209.22	1.27	2.62	0.08
BS173V	8 1/2	8 11/16	3/32	8.487	0.05	0.103	0.003	215.57	1.27	2.62	0.08
BS174V	8 3/4	8 15/16	3/32	8.737	0.05	0.103	0.003	221.92	1.27	2.62	0.08
BS175V	9	9 3/16	3/32	8.987	0.05	0.103	0.003	228.27	1.27	2.62	0.08
BS176V	9 1/4	9 7/16	3/32	9.237	0.055	0.103	0.003	234.62	1.4	2.62	0.08
BS177V	9 1/2	9 11/16	3/32	9.487	0.055	0.103	0.003	240.97	1.4	2.62	0.08
BS178V	9 3/4	9 15/16	3/32	9.737	0.055	0.103	0.003	247.32	1.4	2.62	0.08
BS201V	3/16	7/16	1/8	0.171	0.005	0.139	0.004	4.34	0.13	3.53	0.1
BS202V	1/4	1/2	1/8	0.234	0.005	0.139	0.004	5.94	0.13	3.53	0.1
BS203V	5/16	9/16	1/8	0.296	0.005	0.139	0.004	7.52	0.13	3.53	0.1
BS204V	3/8	5/8	1/8	0.359	0.005	0.139	0.004	9.12	0.13	3.53	0.1
BS205V	7/16	11/16	1/8	0.421	0.005	0.139	0.004	10.69	0.13	3.53	0.1
BS206V	1/2	3/4	1/8	0.484	0.005	0.139	0.004	12.29	0.13	3.53	0.1
BS207V	9/16	13/16	1/8	0.546	0.007	0.139	0.004	13.87	0.18	3.53	0.1
BS208V	5/8	7/8	1/8	0.609	0.009	0.139	0.004	15.47	0.23	3.53	0.1
BS209V	11/16	15/16	1/8	0.671	0.009	0.139	0.004	17.04	0.23	3.53	0.1
BS210V	3/4	1	1/8	0.734	0.01	0.139	0.004	18.64	0.25	3.53	0.1
BS211V	13/16	1 1/16	1/8	0.796	0.01	0.139	0.004	20.22	0.25	3.53	0.1
BS212V	7/8	1 1/8	1/8	0.859	0.01	0.139	0.004	21.82	0.25	3.53	0.1
BS213V	15/16	1 3/16	1/8	0.921	0.01	0.139	0.004	23.39	0.25	3.53	0.1
BS214V	1	1 1/4	1/8	0.984	0.01	0.139	0.004	24.99	0.25	3.53	0.1
BS215V	1 1/16	1 5/16	1/8	1.046	0.01	0.139	0.004	26.57	0.25	3.53	0.1
BS216V	1 1/8	1 3/8	1/8	1.109	0.012	0.139	0.004	28.17	0.3	3.53	0.1
BS217V	1 3/16	1 7/16	1/8	1.171	0.012	0.139	0.004	29.74	0.3	3.53	0.1
BS218V	1 1/4	1 1/2	1/8	1.234	0.012	0.139	0.004	31.34	0.3	3.53	0.1
BS219V	1 5/16	1 9/16	1/8	1.296	0.012	0.139	0.004	32.92	0.3	3.53	0.1
BS220V	1 3/8	1 5/8	1/8	1.359	0.012	0.139	0.004	34.52	0.3	3.53	0.1

BS Series Viton O-Rings (75 Viton)

SIZE	Nominal (Reference)			Measurement (Inch)				Measurement (mm)			
	ID	OD	CS	ID	±	CS	±	ID	±	CS	±
BS221V	1 7/16	1 11/16	1/8	1.421	0.012	0.139	0.004	36.09	0.3	3.53	0.1
BS222V	1 1/2	1 3/4	1/8	1.484	0.015	0.139	0.004	37.69	0.38	3.53	0.1
BS223V	1 5/8	1 7/8	1/8	1.609	0.015	0.139	0.004	40.87	0.38	3.53	0.1
BS224V	1 3/4	2	1/8	1.734	0.015	0.139	0.004	44.04	0.38	3.53	0.1
BS225V	1 7/8	2 1/8	1/8	1.859	0.018	0.139	0.004	47.22	0.46	3.53	0.1
BS226V	2	2 1/4	1/8	1.984	0.018	0.139	0.004	50.39	0.46	3.53	0.1
BS227V	2 1/16	2 3/8	1/8	2.109	0.018	0.139	0.004	53.57	0.46	3.53	0.1
BS228V	2 1/4	2 1/2	1/8	2.234	0.02	0.139	0.004	56.74	0.51	3.53	0.1
BS229V	2 3/8	2 5/8	1/8	2.359	0.02	0.139	0.004	59.92	0.51	3.53	0.1
BS230V	2 1/2	2 3/4	1/8	2.484	0.02	0.139	0.004	63.09	0.51	3.53	0.1
BS231V	2 5/8	2 7/8	1/8	2.609	0.02	0.139	0.004	66.27	0.51	3.53	0.1
BS232V	2 3/4	3	1/8	2.734	0.024	0.139	0.004	69.44	0.61	3.53	0.1
BS233V	2 7/8	3 1/8	1/8	2.859	0.024	0.139	0.004	72.62	0.61	3.53	0.1
BS234V	3	3 1/4	1/8	2.984	0.024	0.139	0.004	75.79	0.61	3.53	0.1
BS235V	3 1/8	3 3/8	1/8	3.109	0.024	0.139	0.004	78.97	0.61	3.53	0.1
BS236V	3 1/4	3 1/2	1/8	3.234	0.024	0.139	0.004	82.14	0.61	3.53	0.1
BS237V	3 3/8	3 5/8	1/8	3.359	0.024	0.139	0.004	85.32	0.61	3.53	0.1
BS238V	3 1/2	3 3/4	1/8	3.484	0.024	0.139	0.004	88.49	0.61	3.53	0.1
BS239V	3 5/8	3 7/8	1/8	3.609	0.028	0.139	0.004	91.67	0.71	3.53	0.1
BS240V	3 3/4	4	1/8	3.734	0.028	0.139	0.004	94.84	0.71	3.53	0.1
BS241V	3 7/8	4 1/8	1/8	3.859	0.028	0.139	0.004	98.02	0.71	3.53	0.1
BS242V	4	4 1/4	1/8	3.984	0.028	0.139	0.004	101.19	0.71	3.53	0.1
BS243V	4 1/8	4 3/8	1/8	4.109	0.028	0.139	0.004	104.37	0.71	3.53	0.1
BS244V	4 1/4	4 1/2	1/8	4.234	0.030	0.139	0.004	107.54	0.76	3.53	0.1
BS245V	4 3/8	4 5/8	1/8	4.359	0.030	0.139	0.004	110.72	0.76	3.53	0.1
BS246V	4 1/2	4 3/4	1/8	4.484	0.030	0.139	0.004	113.89	0.76	3.53	0.1
BS247V	4 5/8	4 7/8	1/8	4.609	0.030	0.139	0.004	117.07	0.76	3.53	0.1
BS248V	4 3/4	5	1/8	4.734	0.030	0.139	0.004	120.24	0.76	3.53	0.1
BS249V	4 7/8	5 1/8	1/8	4.859	0.035	0.139	0.004	123.42	0.89	3.53	0.1
BS250V	5	5 1/4	1/8	4.984	0.035	0.139	0.004	126.59	0.89	3.53	0.1
BS251V	5 1/8	5 3/8	1/8	5.109	0.035	0.139	0.004	129.77	0.89	3.53	0.1
BS252V	5 1/4	5 1/2	1/8	5.234	0.035	0.139	0.004	132.94	0.89	3.53	0.1
BS253V	5 3/8	5 5/8	1/8	5.359	0.035	0.139	0.004	136.12	0.89	3.53	0.1
BS254V	5 1/2	5 3/4	1/8	5.484	0.035	0.139	0.004	139.29	0.89	3.53	0.1
BS255V	5 5/8	5 7/8	1/8	5.609	0.035	0.139	0.004	142.47	0.89	3.53	0.1
BS256V	5 3/4	6	1/8	5.734	0.035	0.139	0.004	145.64	0.89	3.53	0.1
BS257V	5 7/8	6 1/8	1/8	5.859	0.035	0.139	0.004	148.82	0.89	3.53	0.1
BS258V	6	6 1/4	1/8	5.984	0.035	0.139	0.004	151.99	0.89	3.53	0.1
BS259V	6 1/4	6 1/2	1/8	6.234	0.040	0.139	0.004	158.34	1.02	3.53	0.1
BS260V	6 1/2	6 3/4	1/8	6.484	0.040	0.139	0.004	164.69	1.02	3.53	0.1
BS261V	6 3/4	7	1/8	6.734	0.040	0.139	0.004	171.04	1.02	3.53	0.1
BS262V	7	7 1/4	1/8	6.984	0.040	0.139	0.004	177.39	1.02	3.53	0.1
BS263V	7 1/4	7 1/2	1/8	7.234	0.045	0.139	0.004	183.74	1.14	3.53	0.1
BS264V	7 1/2	7 3/4	1/8	7.484	0.045	0.139	0.004	190.09	1.14	3.53	0.1
BS265V	7 3/4	8	1/8	7.734	0.045	0.139	0.004	196.44	1.14	3.53	0.1
BS266V	8	8 1/4	1/8	7.984	0.045	0.139	0.004	202.79	1.14	3.53	0.1
BS267V	8 1/4	8 1/2	1/8	8.234	0.050	0.139	0.004	209.14	1.27	3.53	0.1
BS268V	8 1/2	8 3/4	1/8	8.484	0.050	0.139	0.004	215.49	1.27	3.53	0.1
BS269V	8 3/4	9	1/8	8.734	0.050	0.139	0.004	221.84	1.27	3.53	0.1

BS Series Viton O-Rings (75 Viton)

SIZE	Nominal (Reference)			Measurement (Inch)				Measurement (mm)			
	ID	OD	CS	ID	±	CS	±	ID	±	CS	±
BS270V	9	9 1/4	1/8	8.984	0.050	0.139	0.004	228.19	1.27	3.53	0.1
BS271V	9 1/4	9 1/2	1/8	9.234	0.055	0.139	0.004	234.54	1.4	3.53	0.1
BS272V	9 1/2	9 3/4	1/8	9.484	0.055	0.139	0.004	240.89	1.4	3.53	0.1
BS273V	9 3/4	10	1/8	9.734	0.055	0.139	0.004	247.24	1.4	3.53	0.1
BS274V	10	10 1/4	1/8	9.984	0.055	0.139	0.004	253.59	1.4	3.53	0.1
BS275V	10 1/2	10 3/4	1/8	10.484	0.055	0.139	0.004	266.29	1.4	3.53	0.1
BS276V	11	11 1/4	1/8	10.984	0.065	0.139	0.004	278.99	1.65	3.53	0.1
BS277V	11 1/2	11 3/4	1/8	11.484	0.065	0.139	0.004	291.69	1.65	3.53	0.1
BS278V	12	12 1/4	1/8	11.984	0.065	0.139	0.004	304.39	1.65	3.53	0.1
BS279V	13	13 1/4	1/8	12.984	0.065	0.139	0.004	329.79	1.65	3.53	0.1
BS280V	14	14 1/4	1/8	13.984	0.065	0.139	0.004	355.19	1.65	3.53	0.1
BS281V	15	15 1/4	1/8	14.984	0.065	0.139	0.004	380.59	1.65	3.53	0.1
BS282V	16	16 1/4	1/8	15.955	0.075	0.139	0.004	405.26	1.91	3.53	0.1
BS283V	17	17 1/4	1/8	16.955	0.080	0.139	0.004	430.66	2.03	3.53	0.1
BS284V	18	18 1/4	1/8	17.955	0.085	0.139	0.004	456.06	2.16	3.53	0.1
BS309V	7/16	13/16	3/16	0.412	0.005	0.210	0.005	10.46	0.13	5.33	0.13
BS310V	1/2	7/8	3/16	0.475	0.005	0.210	0.005	12.07	0.13	5.33	0.13
BS311V	9/16	15/16	3/16	0.537	0.007	0.210	0.005	13.64	0.18	5.33	0.13
BS312V	5/8	1	3/16	0.600	0.009	0.210	0.005	15.24	0.23	5.33	0.13
BS313V	11/16	1 1/16	3/16	0.662	0.009	0.210	0.005	16.81	0.23	5.33	0.13
BS314V	3/4	1 1/8	3/16	0.725	0.010	0.210	0.005	18.42	0.25	5.33	0.13
BS315V	13/16	1 3/16	3/16	0.787	0.010	0.210	0.005	19.99	0.25	5.33	0.13
BS316V	7/8	1 1/4	3/16	0.850	0.010	0.210	0.005	21.59	0.25	5.33	0.13
BS317V	15/16	1 5/16	3/16	0.912	0.010	0.210	0.005	23.16	0.25	5.33	0.13
BS318V	1	1 3/8	3/16	0.975	0.010	0.210	0.005	24.77	0.25	5.33	0.13
BS319V	1 1/16	1 7/16	3/16	1.037	0.010	0.210	0.005	26.34	0.25	5.33	0.13
BS320V	1 1/8	1 1/2	3/16	1.100	0.012	0.210	0.005	27.94	0.3	5.33	0.13
BS321V	1 3/16	1 9/16	3/16	1.162	0.012	0.210	0.005	29.51	0.3	5.33	0.13
BS322V	1 1/4	1 5/8	3/16	1.225	0.012	0.210	0.005	31.12	0.3	5.33	0.13
BS323V	1 5/16	1 11/16	3/16	1.287	0.012	0.210	0.005	32.69	0.3	5.33	0.13
BS324V	1 3/8	1 3/4	3/16	1.350	0.012	0.210	0.005	34.29	0.3	5.33	0.13
BS325V	1 1/2	1 7/8	3/16	1.475	0.015	0.210	0.005	37.47	0.38	5.33	0.13
BS326V	1 5/8	2	3/16	1.600	0.015	0.210	0.005	40.64	0.38	5.33	0.13
BS327V	1 3/4	2 1/8	3/16	1.725	0.015	0.210	0.005	43.82	0.38	5.33	0.13
BS328V	1 7/8	2 1/4	3/16	1.850	0.015	0.210	0.005	46.99	0.38	5.33	0.13
BS329V	2	2 3/8	3/16	1.975	0.018	0.210	0.005	50.17	0.46	5.33	0.13
BS330V	2 1/8	2 1/2	3/16	2.100	0.018	0.210	0.005	53.34	0.46	5.33	0.13
BS331V	2 1/4	2 5/8	3/16	2.225	0.018	0.210	0.005	56.52	0.46	5.33	0.13
BS332V	2 3/8	2 3/4	3/16	2.350	0.018	0.210	0.005	59.69	0.46	5.33	0.13
BS333V	2 1/2	2 7/8	3/16	2.475	0.020	0.210	0.005	62.87	0.51	5.33	0.13
BS334V	2 5/8	3	3/16	2.600	0.020	0.210	0.005	66.04	0.51	5.33	0.13
BS335V	2 3/4	3 1/8	3/16	2.725	0.020	0.210	0.005	69.22	0.51	5.33	0.13
BS336V	2 7/8	3 1/4	3/16	2.850	0.020	0.210	0.005	72.39	0.51	5.33	0.13
BS337V	3	3 3/8	3/16	2.975	0.024	0.210	0.005	75.57	0.61	5.33	0.13
BS338V	3 1/8	3 1/2	3/16	3.100	0.024	0.210	0.005	78.74	0.61	5.33	0.13
BS339V	3 1/4	3 5/8	3/16	3.225	0.024	0.210	0.005	81.92	0.61	5.33	0.13
BS340V	3 3/8	3 3/4	3/16	3.350	0.024	0.210	0.005	85.09	0.61	5.33	0.13
BS341V	3 1/2	3 7/8	3/16	3.475	0.024	0.210	0.005	88.27	0.61	5.33	0.13
BS342V	3 5/8	4	3/16	3.600	0.028	0.210	0.005	91.44	0.71	5.33	0.13

BS Series Viton O-Rings (75 Viton)

SIZE	Nominal (Reference)			Measurement (Inch)				Measurement (mm)			
	ID	OD	CS	ID	±	CS	±	ID	±	CS	±
BS343V	3 3/4	4 1/8	3/16	3.725	0.028	0.210	0.005	94.62	0.71	5.33	0.13
BS344V	3 7/8	4 1/4	3/16	3.850	0.028	0.210	0.005	97.79	0.71	5.33	0.13
BS345V	4	4 3/8	3/16	3.975	0.028	0.210	0.005	100.97	0.71	5.33	0.13
BS346V	4 1/8	4 1/2	3/16	4.100	0.028	0.210	0.005	104.14	0.71	5.33	0.13
BS347V	4 1/4	4 5/8	3/16	4.225	0.030	0.210	0.005	107.32	0.76	5.33	0.13
BS348V	4 3/8	4 3/4	3/16	4.350	0.030	0.210	0.005	110.49	0.76	5.33	0.13
BS349V	4 1/2	4 7/8	3/16	4.475	0.030	0.210	0.005	113.67	0.76	5.33	0.13
BS350V	4 5/8	5	3/16	4.600	0.030	0.210	0.005	116.84	0.76	5.33	0.13
BS425V	4 1/2	5	1/4	4.475	0.033	0.275	0.006	113.67	0.84	6.99	0.15
BS426V	4 5/8	5 1/8	1/4	4.600	0.033	0.275	0.006	116.84	0.84	6.99	0.15
BS427V	4 3/4	5 1/4	1/4	4.725	0.033	0.275	0.006	120.02	0.84	6.99	0.15
BS428V	4 7/8	5 3/8	1/4	4.85	0.033	0.275	0.006	123.19	0.84	6.99	0.15
BS429V	5	5 1/2	1/4	4.975	0.037	0.275	0.006	126.37	0.94	6.99	0.15
BS430V	5 1/8	5 5/8	1/4	5.100	0.037	0.275	0.006	129.54	0.94	6.99	0.15
BS431V	5 1/4	5 3/4	1/4	5.225	0.037	0.275	0.006	132.72	0.94	6.99	0.15
BS432V	5 3/8	5 7/8	1/4	5.350	0.037	0.275	0.006	135.89	0.94	6.99	0.15
BS433V	5 1/2	6	1/4	5.475	0.037	0.275	0.006	139.07	0.94	6.99	0.15
BS434V	5 5/8	6 1/8	1/4	5.600	0.037	0.275	0.006	142.24	0.94	6.99	0.15
BS435V	5 3/4	6 1/4	1/4	5.725	0.037	0.275	0.006	145.42	0.94	6.99	0.15
BS436V	5 7/8	6 3/8	1/4	5.850	0.037	0.275	0.006	148.59	0.94	6.99	0.15
BS437V	6	6 1/2	1/4	5.975	0.037	0.275	0.006	151.77	0.94	6.99	0.15
BS438V	6 1/4	6 3/4	1/4	6.225	0.040	0.275	0.006	158.12	1.02	6.99	0.15
BS439V	6 1/2	7	1/4	6.475	0.040	0.275	0.006	164.47	1.02	6.99	0.15
BS440V	6 3/4	7 1/4	1/4	6.725	0.040	0.275	0.006	170.82	1.02	6.99	0.15
BS441V	7	7 1/2	1/4	6.975	0.040	0.275	0.006	177.17	1.02	6.99	0.15
BS442V	7 1/4	7 3/4	1/4	7.225	0.045	0.275	0.006	183.52	1.14	6.99	0.15
BS443V	7 1/2	8	1/4	7.475	0.045	0.275	0.006	189.87	1.14	6.99	0.15
BS444V	7 3/4	8 1/4	1/4	7.725	0.045	0.275	0.006	196.22	1.14	6.99	0.15
BS445V	8	8 1/2	1/4	7.975	0.045	0.275	0.006	202.57	1.14	6.99	0.15
BS446V	8 1/2	9	1/4	8.475	0.055	0.275	0.006	215.27	1.4	6.99	0.15
BS447V	9	9 1/2	1/4	8.975	0.055	0.275	0.006	227.97	1.4	6.99	0.15
BS448V	9 1/2	10	1/4	9.475	0.055	0.275	0.006	240.67	1.4	6.99	0.15
BS449V	10	10 1/2	1/4	9.975	0.055	0.275	0.006	253.37	1.4	6.99	0.15
BS450V	10 1/2	11	1/4	10.475	0.06	0.275	0.006	266.07	1.52	6.99	0.15
BS451V	11	11 1/2	1/4	10.975	0.06	0.275	0.006	278.77	1.52	6.99	0.15
BS452V	11 1/2	12	1/4	11.475	0.06	0.275	0.006	291.47	1.52	6.99	0.15
BS453V	12	12 1/2	1/4	11.975	0.06	0.275	0.006	304.17	1.52	6.99	0.15
BS454V	12 1/2	13	1/4	12.475	0.06	0.275	0.006	316.87	1.52	6.99	0.15
BS455V	13	13 1/2	1/4	12.975	0.06	0.275	0.006	329.57	1.52	6.99	0.15
BS456V	13 1/2	14	1/4	13.475	0.07	0.275	0.006	342.27	1.78	6.99	0.15
BS457V	14	14 1/2	1/4	13.975	0.07	0.275	0.006	354.97	1.78	6.99	0.15
BS458V	14 1/2	15	1/4	14.475	0.07	0.275	0.006	367.67	1.78	6.99	0.15
BS459V	15	15 1/2	1/4	14.975	0.07	0.275	0.006	380.37	1.78	6.99	0.15
BS460V	15 1/2	16	1/4	15.475	0.07	0.275	0.006	393.07	1.78	6.99	0.15
BS461V	16	16 1/2	1/4	15.955	0.075	0.275	0.006	405.26	1.91	6.99	0.15
BS462V	16 1/2	17	1/4	16.455	0.075	0.275	0.006	417.96	1.91	6.99	0.15
BS463V	17	17 1/2	1/4	16.955	0.08	0.275	0.006	430.66	2.03	6.99	0.15
BS464V	17 1/2	18	1/4	17.455	0.085	0.275	0.006	443.36	2.16	6.99	0.15
BS465V	18	18 1/2	1/4	17.955	0.085	0.275	0.006	456.06	2.16	6.99	0.15

BS Series Viton O-Rings (75 Viton)

SIZE	Nominal (Reference)			Measurement (Inch)				Measurement (mm)			
	ID	OD	CS	ID	±	CS	±	ID	±	CS	±
BS466V	18 1/2	19	1/4	18.455	0.085	0.275	0.006	468.76	2.16	6.99	0.15
BS467V	19	19 1/2	1/4	18.955	0.09	0.275	0.006	481.46	2.29	6.99	0.15
BS468V	19 1/2	20	1/4	19.455	0.09	0.275	0.006	494.16	2.29	6.99	0.15
BS469V	20	20 1/2	1/4	19.955	0.095	0.275	0.006	506.86	2.41	6.99	0.15
BS470V	21	21 1/2	1/4	20.955	0.095	0.275	0.006	532.26	2.41	6.99	0.15
BS471V	22	22 1/2	1/4	21.955	0.1	0.275	0.006	557.66	2.54	6.99	0.15
BS472V	23	23 1/2	1/4	22.94	0.105	0.275	0.006	582.68	2.67	6.99	0.15
BS473V	24	24 1/2	1/4	23.94	0.11	0.275	0.006	608.08	2.79	6.99	0.15
BS474V	25	25 1/2	1/4	24.94	0.115	0.275	0.006	633.48	2.92	6.99	0.15
BS475V	26	26 1/2	1/4	25.94	0.12	0.275	0.006	658.88	3.05	6.99	0.15

Metric Series Viton O-Rings (75 Viton)

SIZE	Measurements (mm)				Measurements (Inch)				SIZE	Measurements (mm)				Measurements (Inch)			
	ID	±	CS	±	ID	±	CS	±		ID	±	CS	±	ID	±	CS	±
MOR1 x 1V	1	0.12	1	0.07	0.0394	0.0047	0.0394	0.0028	MOR10.5 x 3V	10.5	0.18	3	0.09	0.4134	0.0071	0.1181	0.0035
MOR1.5 x 1V	1.5	0.12	1	0.07	0.0591	0.0047	0.0394	0.0028	MOR11 x 1V	11	0.18	1	0.07	0.4331	0.0071	0.0394	0.0028
MOR1.5 x 1.5V	1.5	0.12	1.5	0.08	0.0591	0.0047	0.0591	0.0031	MOR11 x 1.5V	11	0.18	1.5	0.08	0.4331	0.0071	0.0591	0.0031
MOR2 x 1V	2	0.13	1	0.07	0.0787	0.0051	0.0394	0.0028	MOR11 x 2V	11	0.18	2	0.08	0.4331	0.0071	0.0787	0.0031
MOR2 x 1.5V	2	0.13	1.5	0.08	0.0787	0.0051	0.0591	0.0031	MOR11 x 3V	11	0.18	3	0.09	0.4331	0.0071	0.1181	0.0035
MOR2 x 2V	2	0.13	2	0.08	0.0787	0.0051	0.0787	0.0031	MOR11.5 x 1V	11.5	0.19	1	0.07	0.4528	0.0075	0.0394	0.0028
MOR2.5 x 2V	2.5	0.13	2	0.08	0.0984	0.0051	0.0787	0.0031	MOR12 x 1V	12	0.19	1	0.07	0.4724	0.0075	0.0394	0.0028
MOR3 x 1V	3	0.14	1	0.07	0.1181	0.0055	0.0394	0.0028	MOR12 x 2V	12	0.19	2	0.08	0.4724	0.0075	0.0787	0.0031
MOR3 x 1.5V	3	0.14	1.5	0.08	0.1181	0.0055	0.0591	0.0031	MOR12 x 3V	12	0.19	3	0.09	0.4724	0.0075	0.1181	0.0035
MOR3 x 2V	3	0.14	2	0.08	0.1181	0.0055	0.0787	0.0031	MOR12 x 4V	12	0.19	4	0.1	0.4724	0.0075	0.1575	0.0039
MOR3 x 3V	3	0.14	3	0.09	0.1181	0.0055	0.1181	0.0035	MOR12.5 x 1V	12.5	0.19	1	0.07	0.4921	0.0075	0.0394	0.0028
MOR3.5 x 1V	3.5	0.14	1	0.07	0.1378	0.0055	0.0394	0.0028	MOR12.5 x 1.5V	12.5	0.19	1.5	0.08	0.4921	0.0075	0.0591	0.0031
MOR4 x 1V	4	0.14	1	0.07	0.1575	0.0055	0.0394	0.0028	MOR12.5 x 2V	12.5	0.19	2	0.08	0.4921	0.0075	0.0787	0.0031
MOR4 x 1.5V	4	0.14	1.5	0.08	0.1575	0.0055	0.0591	0.0031	MOR12.5 x 3V	12.5	0.19	3	0.09	0.4921	0.0075	0.1181	0.0035
MOR4 x 2V	4	0.14	2	0.08	0.1575	0.0055	0.0787	0.0031	MOR13 x 1V	13	0.19	1	0.07	0.5118	0.0075	0.0394	0.0028
MOR4 x 3V	4	0.14	3	0.09	0.1575	0.0055	0.1181	0.0035	MOR13 x 1.5V	13	0.19	1.5	0.08	0.5118	0.0075	0.0591	0.0031
MOR4 x 4V	4	0.14	4	0.1	0.1575	0.0055	0.1575	0.0039	MOR13 x 2V	13	0.19	2	0.08	0.5118	0.0075	0.0787	0.0031
MOR5 x 1V	5	0.15	1	0.07	0.1969	0.0059	0.0394	0.0028	MOR13 x 3V	13	0.19	3	0.09	0.5118	0.0075	0.1181	0.0035
MOR5 x 1.5V	5	0.15	1.5	0.08	0.1969	0.0059	0.0591	0.0031	MOR13.5 x 1V	13.5	0.19	1	0.07	0.5315	0.0075	0.0394	0.0028
MOR5 x 2V	5	0.15	2	0.08	0.1969	0.0059	0.0787	0.0031	MOR13.5 x 2V	13.5	0.19	2	0.08	0.5315	0.0075	0.0787	0.0031
MOR5 x 3V	5	0.15	3	0.09	0.1969	0.0059	0.1181	0.0035	MOR13.5 x 3V	13.5	0.19	3	0.09	0.5315	0.0075	0.1181	0.0035
MOR5.5 x 2V	5.5	0.15	2	0.08	0.2165	0.0059	0.0787	0.0031	MOR14 x 1V	14	0.19	1	0.07	0.5512	0.0075	0.0394	0.0028
MOR6 x 1V	6	0.15	1	0.07	0.2362	0.0059	0.0394	0.0028	MOR14 x 1.5V	14	0.19	1.5	0.08	0.5512	0.0075	0.0591	0.0031
MOR6 x 1.5V	6	0.15	1.5	0.08	0.2362	0.0059	0.0591	0.0031	MOR14 x 2V	14	0.19	2	0.08	0.5512	0.0075	0.0787	0.0031
MOR6 x 2V	6	0.15	2	0.08	0.2362	0.0059	0.0787	0.0031	MOR14 x 3V	14	0.19	3	0.09	0.5512	0.0075	0.1181	0.0035
MOR6 x 3V	6	0.15	3	0.09	0.2362	0.0059	0.1181	0.0035	MOR14 x 4V	14	0.19	4	0.1	0.5512	0.0075	0.1575	0.0039
MOR6 x 4V	6	0.15	4	0.1	0.2362	0.0059	0.1575	0.0039	MOR14.5 x 1V	14.5	0.20	1	0.07	0.5709	0.0079	0.0394	0.0028
MOR6.5 x 1V	6.5	0.16	1	0.07	0.2559	0.0063	0.0394	0.0028	MOR14.5 x 2V	14.5	0.20	2	0.08	0.5709	0.0079	0.0787	0.0031
MOR6.5 x 2V	6.5	0.16	2	0.08	0.2559	0.0063	0.0787	0.0031	MOR14.5 x 3V	14.5	0.20	3	0.09	0.5709	0.0079	0.1181	0.0035
MOR7 x 1V	7	0.16	1	0.07	0.2756	0.0063	0.0394	0.0028	MOR15 x 1V	15	0.20	1	0.07	0.5906	0.0079	0.0394	0.0028
MOR7 x 1.5V	7	0.16	1.5	0.08	0.2756	0.0063	0.0591	0.0031	MOR15 x 1.5V	15	0.20	1.5	0.08	0.5906	0.0079	0.0591	0.0031
MOR7 x 2V	7	0.16	2	0.08	0.2756	0.0063	0.0787	0.0031	MOR15 x 2V	15	0.20	2	0.08	0.5906	0.0079	0.0787	0.0031
MOR7 x 3V	7	0.16	3	0.09	0.2756	0.0063	0.1181	0.0035	MOR15 x 3V	15	0.20	3	0.09	0.5906	0.0079	0.1181	0.0035
MOR8 x 1V	8	0.16	1	0.07	0.3150	0.0063	0.0394	0.0028	MOR16 x 1V	16	0.20	1	0.07	0.6299	0.0079	0.0394	0.0028
MOR8 x 1.5V	8	0.16	1.5	0.08	0.3150	0.0063	0.0591	0.0031	MOR16 x 1.5V	16	0.20	1.5	0.08	0.6299	0.0079	0.0591	0.0031
MOR8 x 2V	8	0.16	2	0.08	0.3150	0.0063	0.0787	0.0031	MOR16 x 2V	16	0.20	2	0.08	0.6299	0.0079	0.0787	0.0031
MOR8 x 3V	8	0.16	3	0.09	0.3150	0.0063	0.1181	0.0035	MOR16 x 3V	16	0.20	3	0.09	0.6299	0.0079	0.1181	0.0035
MOR8 x 4V	8	0.16	4	0.1	0.3150	0.0063	0.1575	0.0039	MOR16 x 4V	16	0.20	4	0.1	0.6299	0.0079	0.1575	0.0039
MOR9 x 1V	9	0.17	1	0.07	0.3543	0.0067	0.0394	0.0028	MOR17 x 1V	17	0.21	1	0.07	0.6693	0.0083	0.0394	0.0028
MOR9 x 1.5V	9	0.17	1.5	0.08	0.3543	0.0067	0.0591	0.0031	MOR17 x 1.5	17	0.21	1.5	0.08	0.6693	0.0083	0.0591	0.0031
MOR9 x 2V	9	0.17	2	0.08	0.3543	0.0067	0.0787	0.0031	MOR17 x 2V	17	0.21	2	0.08	0.6693	0.0083	0.0787	0.0031
MOR9 x 3V	9	0.17	3	0.09	0.3543	0.0067	0.1181	0.0035	MOR17 x 3V	17	0.21	3	0.09	0.6693	0.0083	0.1181	0.0035
MOR9.5 x 2V	9.5	0.17	2	0.08	0.3740	0.0067	0.0787	0.0031	MOR17.5 x 2V	17.5	0.21	2	0.08	0.6890	0.0083	0.0787	0.0031
MOR10 x 1V	10	0.17	1	0.07	0.3937	0.0067	0.0394	0.0028	MOR17.5 x 3V	17.5	0.21	3	0.09	0.6890	0.0083	0.1181	0.0035
MOR10 x 1.5V	10	0.17	1.5	0.08	0.3937	0.0067	0.0591	0.0031									
MOR10 x 2V	10	0.17	2	0.08	0.3937	0.0067	0.0787	0.0031									
MOR10 x 3V	10	0.17	3	0.09	0.3937	0.0067	0.1181	0.0035									
MOR10 x 4V	10	0.17	4	0.1	0.3937	0.0067	0.1575	0.0039									
MOR10.5 x 1V	10.5	0.18	1	0.07	0.4134	0.0071	0.0394	0.0028									

Metric Series Viton O-Rings (75 Viton)

SIZE	Measurements (mm)				Measurements (Inch)				SIZE	Measurements (mm)				Measurements (Inch)			
	ID	±	CS	±	ID	±	CS	±		ID	±	CS	±	ID	±	CS	±
MOR18 x 1V	18	0.21	1	0.07	0.7087	0.0083	0.0394	0.0028	MOR28 x 3V	28	0.28	3	0.09	1.1024	0.0110	0.1181	0.0035
MOR18 x 1.5V	18	0.21	1.5	0.08	0.7087	0.0083	0.0591	0.0031	MOR28 x 4V	28	0.28	4	0.1	1.1024	0.0110	0.1575	0.0039
MOR18 x 2V	18	0.21	2	0.08	0.7087	0.0083	0.0787	0.0031	MOR29 x 1.5V	29	0.29	1.5	0.08	1.1417	0.0114	0.0591	0.0031
MOR18 x 3V	18	0.21	3	0.09	0.7087	0.0083	0.1181	0.0035	MOR29 x 2V	29	0.29	2	0.08	1.1417	0.0114	0.0787	0.0031
MOR18 x 4V	18	0.21	4	0.1	0.7087	0.0083	0.1575	0.0039	MOR29 x 3V	29	0.29	3	0.09	1.1417	0.0114	0.1181	0.0035
MOR18.5 x 1.5V	18.5	0.22	1.5	0.08	0.7283	0.0087	0.0591	0.0031	MOR30 x 1.5V	30	0.29	1.5	0.08	1.1811	0.0114	0.0591	0.0031
MOR18.5 x 2V	18.5	0.22	2	0.08	0.7283	0.0087	0.0787	0.0031	MOR30 x 2V	30	0.29	2	0.08	1.1811	0.0114	0.0787	0.0031
MOR19 x 1V	19	0.22	1	0.07	0.7480	0.0087	0.0394	0.0028	MOR30 x 3V	30	0.29	3	0.09	1.1811	0.0114	0.1181	0.0035
MOR19 x 1.5V	19	0.22	1.5	0.08	0.7480	0.0087	0.0591	0.0031	MOR30 x 4V	30	0.29	4	0.1	1.1811	0.0114	0.1575	0.0039
MOR19 x 2V	19	0.22	2	0.08	0.7480	0.0087	0.0787	0.0031	MOR30 x 5V	30	0.29	5	0.13	1.1811	0.0114	0.1969	0.0051
MOR19 x 3V	19	0.22	3	0.09	0.7480	0.0087	0.1181	0.0035	MOR31 x 1.5V	31	0.31	1.5	0.08	1.2205	0.0122	0.0591	0.0031
MOR19.5 x 3V	19.5	0.22	3	0.09	0.7677	0.0087	0.1181	0.0035	MOR31 x 3V	31	0.31	3	0.09	1.2205	0.0122	0.1181	0.0035
MOR20 x 1V	20	0.22	1	0.07	0.7874	0.0087	0.0394	0.0028	MOR32 x 1.5V	32	0.32	1.5	0.08	1.2598	0.0126	0.0591	0.0031
MOR20 x 1.5V	20	0.22	1.5	0.08	0.7874	0.0087	0.0591	0.0031	MOR32 x 2V	32	0.32	2	0.08	1.2598	0.0126	0.0787	0.0031
MOR20 x 2V	20	0.22	2	0.08	0.7874	0.0087	0.0787	0.0031	MOR32 x 3V	32	0.32	3	0.09	1.2598	0.0126	0.1181	0.0035
MOR20 x 3V	20	0.22	3	0.09	0.7874	0.0087	0.1181	0.0035	MOR32 x 4V	32	0.32	4	0.1	1.2598	0.0126	0.1575	0.0039
MOR20 x 4V	20	0.22	4	0.1	0.7874	0.0087	0.1575	0.0039	MOR32 x 5V	32	0.32	5	0.13	1.2598	0.0126	0.1969	0.0051
MOR21 x 1.5V	21	0.23	1.5	0.08	0.8268	0.0091	0.0591	0.0031	MOR33 x 1.5V	33	0.32	1.5	0.08	1.2992	0.0126	0.0591	0.0031
MOR21 x 2V	21	0.23	2	0.08	0.8268	0.0091	0.0787	0.0031	MOR33 x 2V	33	0.32	2	0.08	1.2992	0.0126	0.0787	0.0031
MOR21 x 3V	21	0.23	3	0.09	0.8268	0.0091	0.1181	0.0035	MOR33 x 3V	33	0.32	3	0.09	1.2992	0.0126	0.1181	0.0035
MOR21.5 x 3V	21.5	0.23	3	0.09	0.8465	0.0091	0.1181	0.0035	MOR34 x 1.5V	34	0.33	1.5	0.08	1.3386	0.0130	0.0591	0.0031
MOR22 x 1V	22	0.24	1	0.07	0.8661	0.0094	0.0394	0.0028	MOR34 x 2V	34	0.33	2	0.08	1.3386	0.0130	0.0787	0.0031
MOR22 x 1.5V	22	0.24	1.5	0.08	0.8661	0.0094	0.0591	0.0031	MOR34 x 3V	34	0.33	3	0.09	1.3386	0.0130	0.1181	0.0035
MOR22 x 2V	22	0.24	2	0.08	0.8661	0.0094	0.0787	0.0031	MOR34 x 4V	34	0.33	4	0.1	1.3386	0.0130	0.1575	0.0039
MOR22 x 3V	22	0.24	3	0.09	0.8661	0.0094	0.1181	0.0035	MOR34 x 5V	34	0.33	5	0.13	1.3386	0.0130	0.1969	0.0051
MOR22 x 4V	22	0.24	4	0.1	0.8661	0.0094	0.1575	0.0039	MOR35 x 1.5V	35	0.34	1.5	0.08	1.3780	0.0134	0.0591	0.0031
MOR23 x 1V	23	0.24	1	0.07	0.9055	0.0094	0.0394	0.0028	MOR35 x 3V	35	0.34	3	0.09	1.3780	0.0134	0.1181	0.0035
MOR23 x 1.5V	23	0.24	1.5	0.08	0.9055	0.0094	0.0591	0.0031	MOR35.5 x 3V	35.5	0.34	3	0.09	1.3976	0.0134	0.1181	0.0035
MOR23 x 2V	23	0.24	2	0.08	0.9055	0.0094	0.0787	0.0031	MOR36 x 1.5V	36	0.35	1.5	0.08	1.4173	0.0138	0.0591	0.0031
MOR23 x 3V	23	0.24	3	0.09	0.9055	0.0094	0.1181	0.0035	MOR36 x 2V	36	0.35	2	0.08	1.4173	0.0138	0.0787	0.0031
MOR24 x 1V	24	0.24	1	0.07	0.9449	0.0094	0.0394	0.0028	MOR36 x 3V	36	0.35	3	0.09	1.4173	0.0138	0.1181	0.0035
MOR24 x 1.5V	24	0.24	1.5	0.08	0.9449	0.0094	0.0591	0.0031	MOR36 x 4V	36	0.35	4	0.1	1.4173	0.0138	0.1575	0.0039
MOR24 x 2V	24	0.24	2	0.08	0.9449	0.0094	0.0787	0.0031	MOR36 x 5V	36	0.35	5	0.13	1.4173	0.0138	0.1969	0.0051
MOR24 x 3V	24	0.24	3	0.09	0.9449	0.0094	0.1181	0.0035	MOR37 x 1.5V	37	0.36	1.5	0.08	1.4567	0.0142	0.0591	0.0031
MOR24 x 4V	24	0.24	4	0.1	0.9449	0.0094	0.1575	0.0039	MOR37 x 2V	37	0.36	2	0.08	1.4567	0.0142	0.0787	0.0031
MOR25 x 1V	25	0.25	1	0.07	0.9843	0.0098	0.0394	0.0028	MOR37 x 3V	37	0.36	3	0.09	1.4567	0.0142	0.1181	0.0035
MOR25 x 1.5V	25	0.25	1.5	0.08	0.9843	0.0098	0.0591	0.0031	MOR38 x 1.5V	38	0.36	1.5	0.08	1.4961	0.0142	0.0591	0.0031
MOR25 x 2V	25	0.25	2	0.08	0.9843	0.0098	0.0787	0.0031	MOR38 x 2V	38	0.36	2	0.08	1.4961	0.0142	0.0787	0.0031
MOR25 x 3V	25	0.25	3	0.09	0.9843	0.0098	0.1181	0.0035	MOR38 x 3V	38	0.36	3	0.09	1.4961	0.0142	0.1181	0.0035
MOR26 x 1.5V	26	0.26	1.5	0.08	1.0236	0.0102	0.0591	0.0031	MOR38 x 4V	38	0.36	4	0.1	1.4961	0.0142	0.1575	0.0039
MOR26 x 2V	26	0.26	2	0.08	1.0236	0.0102	0.0787	0.0031	MOR38 x 5V	38	0.36	5	0.13	1.4961	0.0142	0.1969	0.0051
MOR26 x 3V	26	0.26	3	0.09	1.0236	0.0102	0.1181	0.0035	MOR39 x 1.5V	39	0.37	1.5	0.08	1.5354	0.0146	0.0591	0.0031
MOR26 x 4V	26	0.26	4	0.1	1.0236	0.0102	0.1575	0.0039	MOR39 x 2V	39	0.37	2	0.08	1.5354	0.0146	0.0787	0.0031
MOR27 x 1.5V	27	0.26	1.5	0.08	1.0630	0.0102	0.0591	0.0031	MOR39 x 3V	39	0.37	3	0.09	1.5354	0.0146	0.1181	0.0035
MOR27 x 2V	27	0.26	2	0.08	1.0630	0.0102	0.0787	0.0031	MOR39.5 x 3V	39.5	0.37	3	0.09	1.5551	0.0146	0.1181	0.0035
MOR27 x 3V	27	0.26	3	0.09	1.0630	0.0102	0.1181	0.0035	MOR40 x 1.5V	40	0.38	1.5	0.08	1.5748	0.0150	0.0591	0.0031
MOR27.5 x 3V	27.5	0.26	3	0.09	1.0827	0.0102	0.1181	0.0035	MOR40 x 2V	40	0.38	2	0.08	1.5748	0.0150	0.0787	0.0031
MOR28 x 1.5V	28	0.28	1.5	0.08	1.1024	0.0110	0.0591	0.0031	MOR40 x 3V	40	0.38	3	0.09	1.5748	0.0150	0.1181	0.0035
MOR28 x 2V	28	0.28	2	0.08	1.1024	0.0110	0.0787	0.0031	MOR40 x 4V	40	0.38	4	0.1	1.5748	0.0150	0.1575	0.0039

Metric Series Viton O-Rings (75 Viton)

SIZE	Measurements (mm)				Measurements (Inch)				SIZE	Measurements (mm)				Measurements (Inch)			
	ID	±	CS	±	ID	±	CS	±		ID	±	CS	±	ID	±	CS	±
MOR40 x 5V	40	0.38	5	0.13	1.5748	0.0150	0.1969	0.0051	MOR53 x 2V	53	0.48	2	0.08	2.0866	0.0189	0.0787	0.0031
MOR41 x 1.5V	41	0.39	1.5	0.08	1.6142	0.0154	0.0591	0.0031	MOR53 x 3V	53	0.48	3	0.09	2.0866	0.0189	0.1181	0.0035
MOR41 x 2V	41	0.39	2	0.08	1.6142	0.0154	0.0787	0.0031	MOR54 x 2V	54	0.50	2	0.08	2.1260	0.0197	0.0787	0.0031
MOR41 x 3V	41	0.39	3	0.09	1.6142	0.0154	0.1181	0.0035	MOR54 x 3V	54	0.50	3	0.09	2.1260	0.0197	0.1181	0.0035
MOR42 x 1.5V	42	0.40	1.5	0.08	1.6535	0.0157	0.0591	0.0031	MOR54 x 4V	54	0.50	4	0.1	2.1260	0.0197	0.1575	0.0039
MOR42 x 2V	42	0.40	2	0.08	1.6535	0.0157	0.0787	0.0031	MOR54 x 5V	54	0.50	5	0.13	2.1260	0.0197	0.1969	0.0051
MOR42 x 3V	42	0.40	3	0.09	1.6535	0.0157	0.1181	0.0035	MOR54.5 x 3V	54.5	0.50	3	0.09	2.1457	0.0197	0.1181	0.0035
MOR42 x 4V	42	0.40	4	0.1	1.6535	0.0157	0.1575	0.0039	MOR55 x 2V	55	0.50	2	0.08	2.1654	0.0197	0.0787	0.0031
MOR42 x 5V	42	0.40	5	0.13	1.6535	0.0157	0.1969	0.0051	MOR55 x 3V	55	0.50	3	0.09	2.1654	0.0197	0.1181	0.0035
MOR43 x 1.5V	43	0.40	1.5	0.08	1.6929	0.0157	0.0591	0.0031	MOR55 x 6V	55	0.52	6	0.15	2.1654	0.0203	0.2362	0.0059
MOR43 x 2V	43	0.40	2	0.08	1.6929	0.0157	0.0787	0.0031	MOR56 x 2V	56	0.51	2	0.08	2.2047	0.0201	0.0787	0.0031
MOR43 x 3V	43	0.40	3	0.09	1.6929	0.0157	0.1181	0.0035	MOR56 x 3V	56	0.51	3	0.09	2.2047	0.0201	0.1181	0.0035
MOR44 x 2V	44	0.41	2	0.08	1.7323	0.0161	0.0787	0.0031	MOR56 x 4V	56	0.51	4	0.1	2.2047	0.0201	0.1575	0.0039
MOR44 x 3V	44	0.41	3	0.09	1.7323	0.0161	0.1181	0.0035	MOR57 x 2V	57	0.52	2	0.08	2.2441	0.0205	0.0787	0.0031
MOR44 x 4V	44	0.41	4	0.1	1.7323	0.0161	0.1575	0.0039	MOR57 x 3V	57	0.52	3	0.09	2.2441	0.0205	0.1181	0.0035
MOR44 x 5V	44	0.41	5	0.13	1.7323	0.0161	0.1969	0.0051	MOR58 x 2V	58	0.52	2	0.08	2.2835	0.0205	0.0787	0.0031
MOR44.5 x 3V	44.5	0.41	3	0.09	1.7520	0.0161	0.1181	0.0035	MOR58 x 3V	58	0.52	3	0.09	2.2835	0.0205	0.1181	0.0035
MOR45 x 1.5V	45	0.42	1.5	0.08	1.7717	0.0165	0.0591	0.0031	MOR58 x 4V	58	0.52	4	0.1	2.2835	0.0205	0.1575	0.0039
MOR45 x 2V	45	0.42	2	0.08	1.7717	0.0165	0.0787	0.0031	MOR58 x 5V	58	0.52	5	0.13	2.2835	0.0205	0.1969	0.0051
MOR45 x 3V	45	0.42	3	0.09	1.7717	0.0165	0.1181	0.0035	MOR59 x 2V	59	0.54	2	0.08	2.3228	0.0213	0.0787	0.0031
MOR46 x 1.5V	46	0.43	1.5	0.08	1.8110	0.0169	0.0591	0.0031	MOR59 x 3V	59	0.54	3	0.09	2.3228	0.0213	0.1181	0.0035
MOR46 x 2V	46	0.43	2	0.08	1.8110	0.0169	0.0787	0.0031	MOR59.5 x 3V	59.5	0.54	3	0.09	2.3425	0.0213	0.1181	0.0035
MOR46 x 3V	46	0.43	3	0.09	1.8110	0.0169	0.1181	0.0035	MOR60 x 2V	60	0.54	2	0.08	2.3622	0.0213	0.0787	0.0031
MOR46 x 4V	46	0.43	4	0.1	1.8110	0.0169	0.1575	0.0039	MOR60 x 3V	60	0.54	3	0.09	2.3622	0.0213	0.1181	0.0035
MOR46 x 5V	46	0.43	5	0.13	1.8110	0.0169	0.1969	0.0051	MOR60 x 4V	60	0.54	4	0.1	2.3622	0.0213	0.1575	0.0039
MOR47 x 1.5V	47	0.44	1.5	0.08	1.8504	0.0173	0.0591	0.0031	MOR60 x 5V	60	0.54	5	0.13	2.3622	0.0213	0.1969	0.0051
MOR47 x 2V	47	0.44	2	0.08	1.8504	0.0173	0.0787	0.0031	MOR60 x 6V	60	0.55	6	0.15	2.3622	0.0217	0.2362	0.0059
MOR47 x 3V	47	0.44	3	0.09	1.8504	0.0173	0.1181	0.0035	MOR62 x 2V	62	0.55	2	0.08	2.4409	0.0217	0.0787	0.0031
MOR48 x 1.5V	48	0.44	1.5	0.08	1.8898	0.0173	0.0591	0.0031	MOR62 x 3V	62	0.55	3	0.09	2.4409	0.0217	0.1181	0.0035
MOR48 x 2V	48	0.44	2	0.08	1.8898	0.0173	0.0787	0.0031	MOR62 x 4V	62	0.55	4	0.1	2.4409	0.0217	0.1575	0.0039
MOR48 x 3V	48	0.44	3	0.09	1.8898	0.0173	0.1181	0.0035	MOR62 x 5V	62	0.55	5	0.13	2.4409	0.0217	0.1969	0.0051
MOR48 x 4V	48	0.44	4	0.1	1.8898	0.0173	0.1575	0.0039	MOR64 x 2V	64	0.58	2	0.08	2.5197	0.0228	0.0787	0.0031
MOR48 x 5V	48	0.44	5	0.13	1.8898	0.0173	0.1969	0.0051	MOR64 x 3V	64	0.58	3	0.09	2.5197	0.0228	0.1181	0.0035
MOR49 x 1.5V	49	0.45	1.5	0.08	1.9291	0.0177	0.0591	0.0031	MOR64 x 4V	64	0.58	4	0.1	2.5197	0.0228	0.1575	0.0039
MOR49 x 2V	49	0.45	2	0.08	1.9291	0.0177	0.0787	0.0031	MOR64 x 5V	64	0.58	5	0.13	2.5197	0.0228	0.1969	0.0051
MOR49 x 3V	49	0.45	3	0.09	1.9291	0.0177	0.1181	0.0035	MOR65 x 6V	65	0.58	6	0.15	2.5591	0.0230	0.2362	0.0059
MOR49.5 x 3V	49.5	0.45	3	0.09	1.9488	0.0177	0.1181	0.0035	MOR66 x 2V	66	0.59	2	0.08	2.5984	0.0232	0.0787	0.0031
MOR50 x 1.5V	50	0.46	1.5	0.08	1.9685	0.0181	0.0591	0.0031	MOR66 x 3V	66	0.59	3	0.09	2.5984	0.0232	0.1181	0.0035
MOR50 x 2V	50	0.46	2	0.08	1.9685	0.0181	0.0787	0.0031	MOR66 x 4V	66	0.59	4	0.1	2.5984	0.0232	0.1575	0.0039
MOR50 x 3V	50	0.46	3	0.09	1.9685	0.0181	0.1181	0.0035	MOR66 x 5V	66	0.59	5	0.13	2.5984	0.0232	0.1969	0.0051
MOR50 x 4V	50	0.46	4	0.1	1.9685	0.0181	0.1575	0.0039	MOR68 x 2V	68	0.61	2	0.08	2.6772	0.0240	0.0787	0.0031
MOR50 x 5V	50	0.46	5	0.13	1.9685	0.0181	0.1969	0.0051	MOR68 x 3V	68	0.61	3	0.09	2.6772	0.0240	0.1181	0.0035
MOR50 x 6V	50	0.48	6	0.15	1.9685	0.0189	0.2362	0.0059	MOR68 x 4V	68	0.61	4	0.1	2.6772	0.0240	0.1575	0.0039
MOR51 x 2V	51	0.47	2	0.08	2.0079	0.0185	0.0787	0.0031	MOR68 x 5V	68	0.61	5	0.13	2.6772	0.0240	0.1969	0.0051
MOR51 x 3V	51	0.47	3	0.09	2.0079	0.0185	0.1181	0.0035	MOR70 x 2V	70	0.62	2	0.08	2.7559	0.0244	0.0787	0.0031
MOR52 x 2V	52	0.47	2	0.08	2.0472	0.0185	0.0787	0.0031	MOR70 x 3V	70	0.62	3	0.09	2.7559	0.0244	0.1181	0.0035
MOR52 x 3V	52	0.47	3	0.09	2.0472	0.0185	0.1181	0.0035	MOR70 x 4V	70	0.62	4	0.1	2.7559	0.0244	0.1575	0.0039
MOR52 x 4V	52	0.47	4	0.1	2.0472	0.0185	0.1575	0.0039	MOR70 x 5V	70	0.62	5	0.13	2.7559	0.0244	0.1969	0.0051
MOR52 x 5V	52	0.47	5	0.13	2.0472	0.0185	0.1969	0.0051	MOR70 x 6V	70	0.62	6	0.15	2.7559	0.0244	0.2362	0.0059

Metric Series Viton O-Rings (75 Viton)

SIZE	Measurements (mm)				Measurements (Inch)				SIZE	Measurements (mm)				Measurements (Inch)			
	ID	±	CS	±	ID	±	CS	±		ID	±	CS	±	ID	±	CS	±
MOR72 x 2V	72	0.63	2	0.08	2.8346	0.0248	0.0787	0.0031	MOR94 x 5V	94	0.78	5	0.13	3.7008	0.0307	0.1969	0.0051
MOR72 x 3V	72	0.63	3	0.09	2.8346	0.0248	0.1181	0.0035	MOR95 x 3V	95	0.79	3	0.09	3.7402	0.0311	0.1181	0.0035
MOR72 x 4V	72	0.63	4	0.1	2.8346	0.0248	0.1575	0.0039	MOR95 x 6V	95	0.79	6	0.15	3.7402	0.0311	0.2362	0.0059
MOR72 x 5V	72	0.63	5	0.13	2.8346	0.0248	0.1969	0.0051	MOR96 x 2V	96	0.80	2	0.08	3.7795	0.0315	0.0787	0.0031
MOR74 x 2V	74	0.65	2	0.08	2.9134	0.0256	0.0787	0.0031	MOR96 x 4V	96	0.80	4	0.1	3.7795	0.0315	0.1575	0.0039
MOR74 x 3V	74	0.65	3	0.09	2.9134	0.0256	0.1181	0.0035	MOR96 x 5V	96	0.80	5	0.13	3.7795	0.0315	0.1969	0.0051
MOR74 x 4V	74	0.65	4	0.1	2.9134	0.0256	0.1575	0.0039	MOR98 x 2V	98	0.81	2	0.08	3.8583	0.0319	0.0787	0.0031
MOR74 x 5V	74	0.65	5	0.13	2.9134	0.0256	0.1969	0.0051	MOR98 x 3V	98	0.81	3	0.09	3.8583	0.0319	0.1181	0.0035
MOR75 x 6V	75	0.65	6	0.15	2.9528	0.0257	0.2362	0.0059	MOR98 x 4V	98	0.81	4	0.1	3.8583	0.0319	0.1575	0.0039
MOR76 x 2V	76	0.66	2	0.08	2.9921	0.0260	0.0787	0.0031	MOR98 x 5V	98	0.81	5	0.13	3.8583	0.0319	0.1969	0.0051
MOR76 x 3V	76	0.66	3	0.09	2.9921	0.0260	0.1181	0.0035	MOR100 x 2V	100	0.82	2	0.08	3.9370	0.0323	0.0787	0.0031
MOR76 x 4V	76	0.66	4	0.1	2.9921	0.0260	0.1575	0.0039	MOR100 x 3V	100	0.82	3	0.09	3.9370	0.0323	0.1181	0.0035
MOR76 x 5V	76	0.66	5	0.13	2.9921	0.0260	0.1969	0.0051	MOR100 x 4V	100	0.82	4	0.1	3.9370	0.0323	0.1575	0.0039
MOR78 x 2V	78	0.67	2	0.08	3.0709	0.0264	0.0787	0.0031	MOR100 x 5V	100	0.82	5	0.13	3.9370	0.0323	0.1969	0.0051
MOR78 x 3V	78	0.67	3	0.09	3.0709	0.0264	0.1181	0.0035	MOR100 x 6V	100	0.82	6	0.15	3.9370	0.0325	0.2362	0.0059
MOR78 x 4V	78	0.67	4	0.1	3.0709	0.0264	0.1575	0.0039	MOR105 x 3V	105	0.86	3	0.09	4.1339	0.0339	0.1181	0.0035
MOR78 x 5V	78	0.67	5	0.13	3.0709	0.0264	0.1969	0.0051	MOR105 x 4V	105	0.86	4	0.1	4.1339	0.0339	0.1575	0.0039
MOR80 x 2V	80	0.69	2	0.08	3.1496	0.0272	0.0787	0.0031	MOR105 x 5V	105	0.86	5	0.13	4.1339	0.0339	0.1969	0.0051
MOR80 x 3V	80	0.69	3	0.09	3.1496	0.0272	0.1181	0.0035	MOR105 x 6V	105	0.86	6	0.15	4.1339	0.0338	0.2362	0.0059
MOR80 x 4V	80	0.69	4	0.1	3.1496	0.0272	0.1575	0.0039	MOR110 x 3V	110	0.89	3	0.09	4.3307	0.0350	0.1181	0.0035
MOR80 x 5V	80	0.69	5	0.13	3.1496	0.0272	0.1969	0.0051	MOR110 x 4V	110	0.89	4	0.1	4.3307	0.0350	0.1575	0.0039
MOR80 x 6V	80	0.69	6	0.15	3.1496	0.0271	0.2362	0.0059	MOR110 x 5V	110	0.89	5	0.13	4.3307	0.0350	0.1969	0.0051
MOR82 x 2V	82	0.70	2	0.08	3.2283	0.0276	0.0787	0.0031	MOR110 x 6V	110	0.89	6	0.15	4.3307	0.0351	0.2362	0.0059
MOR82 x 3V	82	0.70	3	0.09	3.2283	0.0276	0.1181	0.0035	MOR115 x 3V	115	0.93	3	0.09	4.5276	0.0366	0.1181	0.0035
MOR82 x 4V	82	0.70	4	0.1	3.2283	0.0276	0.1575	0.0039	MOR115 x 4V	115	0.93	4	0.1	4.5276	0.0366	0.1575	0.0039
MOR82 x 5V	82	0.70	5	0.13	3.2283	0.0276	0.1969	0.0051	MOR115 x 5V	115	0.93	5	0.13	4.5276	0.0366	0.1969	0.0051
MOR84 x 2V	84	0.72	2	0.08	3.3071	0.0283	0.0787	0.0031	MOR115 x 6V	115	0.93	6	0.15	4.5276	0.0365	0.2362	0.0059
MOR84 x 3V	84	0.72	3	0.09	3.3071	0.0283	0.1181	0.0035	MOR120 x 3V	120	0.96	3	0.09	4.7244	0.0378	0.1181	0.0035
MOR84 x 4V	84	0.72	4	0.1	3.3071	0.0283	0.1575	0.0039	MOR120 x 4V	120	0.96	4	0.1	4.7244	0.0378	0.1575	0.0039
MOR84 x 5V	84	0.72	5	0.13	3.3071	0.0283	0.1969	0.0051	MOR120 x 5V	120	0.96	5	0.13	4.7244	0.0378	0.1969	0.0051
MOR85 x 6V	85	0.72	6	0.15	3.3465	0.0284	0.2362	0.0059	MOR120 x 6V	120	0.96	6	0.15	4.7244	0.0378	0.2362	0.0059
MOR86 x 2V	86	0.73	2	0.08	3.3858	0.0287	0.0787	0.0031	MOR125 x 3V	125	0.99	3	0.09	4.9213	0.0390	0.1181	0.0035
MOR86 x 3V	86	0.73	3	0.09	3.3858	0.0287	0.1181	0.0035	MOR125 x 4V	125	0.99	4	0.1	4.9213	0.0390	0.1575	0.0039
MOR86 x 4V	86	0.73	4	0.1	3.3858	0.0287	0.1575	0.0039	MOR125 x 5V	125	0.99	5	0.13	4.9213	0.0390	0.1969	0.0051
MOR86 x 5V	86	0.73	5	0.13	3.3858	0.0287	0.1969	0.0051	MOR125 x 6V	125	0.99	6	0.15	4.9213	0.0391	0.2362	0.0059
MOR88 x 3V	88	0.74	3	0.09	3.4646	0.0291	0.1181	0.0035	MOR130 x 3V	130	1.03	3	0.09	5.1181	0.0406	0.1181	0.0035
MOR88 x 4V	88	0.74	4	0.1	3.4646	0.0291	0.1575	0.0039	MOR130 x 4V	130	1.03	4	0.1	5.1181	0.0406	0.1575	0.0039
MOR88 x 5V	88	0.74	5	0.13	3.4646	0.0291	0.1969	0.0051	MOR130 x 5V	130	1.03	5	0.13	5.1181	0.0406	0.1969	0.0051
MOR90 x 2V	90	0.76	2	0.08	3.5433	0.0299	0.0787	0.0031	MOR130 x 6V	130	1.03	6	0.15	5.1181	0.0404	0.2362	0.0059
MOR90 x 3V	90	0.76	3	0.09	3.5433	0.0299	0.1181	0.0035	MOR135 x 3V	135	1.06	3	0.09	5.3150	0.0417	0.1181	0.0035
MOR90 x 4V	90	0.76	4	0.1	3.5433	0.0299	0.1575	0.0039	MOR135 x 4V	135	1.06	4	0.1	5.3150	0.0417	0.1575	0.0039
MOR90 x 5V	90	0.76	5	0.13	3.5433	0.0299	0.1969	0.0051	MOR135 x 5V	135	1.06	5	0.13	5.3150	0.0417	0.1969	0.0051
MOR90 x 6V	90	0.76	6	0.15	3.5433	0.0298	0.2362	0.0059	MOR135 x 6V	135	1.06	6	0.15	5.3150	0.0418	0.2362	0.0059
MOR92 x 2V	92	0.77	2	0.08	3.6220	0.0303	0.0787	0.0031	MOR140 x 3V	140	1.09	3	0.09	5.5118	0.0429	0.1181	0.0035
MOR92 x 3V	92	0.77	3	0.09	3.6220	0.0303	0.1181	0.0035	MOR140 x 4V	140	1.09	4	0.1	5.5118	0.0429	0.1575	0.0039
MOR92 x 4V	92	0.77	4	0.1	3.6220	0.0303	0.1575	0.0039	MOR140 x 5V	140	1.09	5	0.13	5.5118	0.0429	0.1969	0.0051
MOR92 x 5V	92	0.77	5	0.13	3.6220	0.0303	0.1969	0.0051	MOR140 x 6V	140	1.09	6	0.15	5.5118	0.0431	0.2362	0.0059
MOR94 x 2V	94	0.78	2	0.08	3.7008	0.0307	0.0787	0.0031	MOR145 x 3V	145	1.13	3	0.09	5.7087	0.0445	0.1181	0.0035
MOR94 x 4V	94	0.78	4	0.1	3.7008	0.0307	0.1575	0.0039	MOR145 x 4V	145	1.13	4	0.1	5.7087	0.0445	0.1575	0.0039

Metric Series Viton O-Rings (75 Viton)

SIZE	Measurements (mm)				Measurements (Inch)			
	ID	±	CS	±	ID	±	CS	±
MOR145 x 5V	145	1.13	5	0.13	5.7087	0.0445	0.1969	0.0051
MOR145 x 6V	145	1.13	6	0.15	5.7087	0.0444	0.2362	0.0059
MOR150 x 3V	150	1.16	3	0.09	5.9055	0.0457	0.1181	0.0035
MOR150 x 4V	150	1.16	4	0.1	5.9055	0.0457	0.1575	0.0039
MOR150 x 5V	150	1.16	5	0.13	5.9055	0.0457	0.1969	0.0051
MOR150 x 6V	150	1.16	6	0.15	5.9055	0.0457	0.2362	0.0059

O-Ring Cord (NBR 70 Duro)

O-Ring Cord Sizing - Metric		
ORC-1.5MM	ORC-5.5MM	ORC-10MM
ORC-1.6MM	ORC-5.7MM	ORC-10.5MM
ORC-2MM	ORC-6MM	ORC-11MM
ORC-2.4MM	ORC-6.35MM	ORC-11.5MM
ORC-2.5MM	ORC-6.5MM	ORC-12MM
ORC-3MM	ORC-7MM	ORC-13MM
ORC-3.2MM	ORC-7.5MM	ORC-14MM
ORC-3.5MM	ORC-8MM	ORC-14.5MM
ORC-4MM	ORC-8.4MM	ORC-15MM
ORC-4.5MM	ORC-8.5MM	ORC-16MM
ORC-4.75MM	ORC-9MM	
ORC-5MM	ORC-9.5MM	
O-Ring Cord Sizing - Imperial		
ORC-1/16	ORC-3/32	ORC-1/8
ORC-3/16	ORC-1/4	ORC-1/2

Shaft Repair Sleeves (Metric & Imperial)

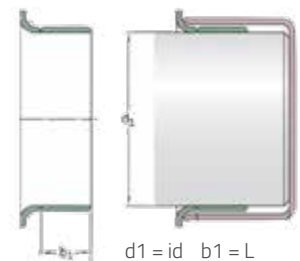

Part No.	Dimension (id x L)	Part No.	Dimension (id x L)	Part No.	Dimension (id x L)
99049	12 x 7mm	99174	1.750 x 0.562 / 1-3/4 x 9/16	99298	76.02 x 14.30mm / 76.02mm x 9/16"
99050	0.500 x 0.250 / 1/2 x 1/4	99175	1.750 x 0.750 / 1-3/4 x 3/4	99299	3.000 x 0.813 / 3 x 13/16
99055	14 x 6.35mm / 14mm x 1/4"	99176	44.8 x 14.3mm / 1-49/64 x 9/16	99300	3.000 x 0.813 / 3 x 13/16
99056	14.3 x 6.35mm / 9/16mm x 1/4"	99177	45 x 14mm	99303	3.150 x 0.750 / 80.01mm x 3/4"
99058	16 x 7.95mm / 16mm x 5/16"	99179	45.24 x 16.94mm	99306	3.150 x 0.750 / 80.01mm x 3/4"
99059	15 x 5mm	99181	1.813 x 0.563 / 1-13/16 x 9/16	99313	3.150 x 0.750 / 80.01mm x 3/4"
99060	17.37 x 7.95mm / 11/16 x 5/16"	99182	43 x 12.7mm / 43mm x 1/2"	99315	80 x 21mm
99062	0.625 x 0.313 / 5/8 x 5/16	99184	1.875 x 0.375 / 1-7/8 x 3/8	99317	80.01 x 11mm
99068	17 x 8mm	99185	1.859 x 0.562 / 1-55/64 x 9/16	99325	3.250 x 0.813 / 3-1/4 x 13/16

Shaft Repair Sleeves (Metric & Imperial)

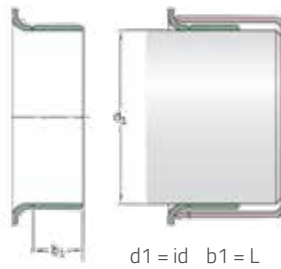

Part No.	Dimension (id x L)	Part No.	Dimension (id x L)	Part No.	Dimension (id x L)
99076	0.750 x 0.313 / 3/4 x 5/16	99187	1.875 x 0.563 / 1-7/8 x 9/16	99328	82 x 16.76mm
99078	20 x 8mm	99188	47.63 x 7.49mm / 1-7/8 x 19/64	99333	85 x 21mm
99080	0.781 x 0.312 / 25/32 x 5/16	99189	48 x 14mm	99334	85 x 10.13mm
99082	18 x 8mm	99193	1.938 x 0.563 / 1-15/16 x 9/16	99337	3.375 x 0.813 / 3-3/8 x 13/16
99084	22 x 6.58mm	99196	50 x 14mm	99347	3.500 x 0.312 / 3-1/2 x 5/16"
99085	22 x 8mm	99199	2.000 x 0.562 / 2 x 9/16	99349	89 x 15.88mm / 89mm x 5/8"
99086	0.859 x 0.250 / 55/64 x 1/4	99200	2.000 x 0.875 / 2 x 7/8	99350	3.500 x 0.813 / 3-1/2 x 13/16
99087	0.875 x 0.313 / 7/8 x 5/16	99204	52 x 12.7mm / 52mm x 1/2"	99351	90 x 18.03mm
99092	24 x 7.95mm / 24mm x 5/16"	99210	2.125 x 0.500 / 2-1/8 x 1/2	99353	90 x 13.36mm
99096	0.969 x 0.625 / 31/32 x 5/8	99212	2.125 x 0.781 / 2-1/8 x 25/32	99354	90 x 23.01mm / 90mm x 29/32"
99098	25 x 7.95mm / 25mm x 5/16"	99215	55 x 20mm	99356	3.562 x 0.906 / 3-9/16 x 29/32
99100	1.000 x 0.313 / 1 x 5/16	99218	2.187 x 0.781 / 2-3/16 x 25/32	99359	94.74 x 11.91mm / 94.74mm x 15/32"
99103	26 x 8mm	99219	58 x 20mm	99360	91.97 x 20.65mm / 91.97mm x 13/16"
99106	27 x 7.95mm / 1-1/16 x 5/16	99220	56.01 x 12.70mm / 2-13/64 x 1/2	99362	3.625 x 0.813 / 3-5/8 x 13/16
99111	28 x 9.53mm / 28mm x 3/8"	99225	2.250 x 0.781 / 2-1/4 x 25/32	99363	3.625 x 0.500 / 3-5/8 x 1/2
99112	1.125 x 0.313 / 1-1/8 x 5/16	99227	2.250 x 0.312 / 2-1/4 x 5/16	99364	95.07 x 11.91mm / 3.742 x 0.468
99114	30 x 8mm	99229	56.64 x 12.70mm / 2-15/64 x 1/2	99367	95.33 x 8.74mm / 3.753 x 0.343
99116	1.125 x 0.375 / 1-1/8 x 3/8	99233	2.250 x 0.781 / 2-1/4 x 25/32	99368	3.688 x 0.313 / 3-11/16 x 5/16
99118	1.188 x 0.313 / 1-3/16 x 5/16	99235	60 x 20mm	99369	95 x 21.01mm
99122	1.171 x 0.312 / 1-11/64 x 5/16	99237	2.375 x 0.781 / 2-3/8 x 25/32	99372	3.750 x 0.688 / 3-3/4 x 11/16
99125	1.250 x 0.313 / 1-1/4 x 5/16	99238	2.375 x 0.593 / 2-3/8 x 19/32	99374	3.75 x 0.345 / 3-3/4 x 11/32"
99128	32 x 8mm	99240	2.375 x 0.513 / 2-3/8 x 17/32	99387	3.875 x 1.875 / 3-7/8 x 1-7/8"
99131	1.3125 x 0.500 / 1-5/16 x 1/2	99241	60 x 9.40mm	99393	3.938 x 0.813 / 3-15/16 x 13/16
99134	34 x 12.7mm / 34mm x 1/2"	99242	62 x 12.7mm / 62mm x 1/2"	99399	4.000 x 0.812 / 4 x 13/16
99138	1.375 x 0.500 / 1-3/8 x 1/2	99243	2.437 x 0.781 / 2-7/16 x 25/32	99400	4.000 x 0.650 / 4 x 16.51mm"
99139	35 x 13mm	99244	2.438 x 12.7 / 2-7/16 x 1/2	99409	104 x 20mm
99143	1.438 x 0.563 / 1-7/16 x 9/16	99248	2.500 x 0.500 / 2-1/2 x 1/2	99412	4.125 x 0.812 / 4-1/8 x 13/16
99144	1.437 x 0.375 / 1-7/16 x 3/8	99250	2.500 x 0.781 / 2-1/2 x 25/32	99413	105 x 20mm
99146	36 x 13mm	99253	63.50 x 14.10mm / 2-1/2 x 14.10mm"	99418	4.188 x 0.812 / 4-3/16 x 13/16
99147	38 x 13mm	99254	65 x 20mm	99424	4.250 x 0.813 / 4-1/4 x 13/16
99149	1.500 x 0.563 / 1-1/2 x 9/16	99256	2.562 x 0.781 / 2-9/16 x 25/32	99434	100 x 11.38mm
99150	1.500 x 0.375 / 1-1/2 x 3/8	99259	66 x 20mm	99435	110 x 12.93mm
99152	1.523 x 0.438 / 38.68mm x 7/16"	99260	2.625 x 0.500 / 2-5/8 x 1/2	99437	4.375 x 0.813 / 4-3/8 x 13/16
99155	39.42 x 11.13mm / 1-35/64 x 7/16	99261	66.57 x 19.48mm / 2-5/8 x 25/32	99450	4.500 x 0.813 / 4-1/2 x 13/16
99156	1.562 x 0.562 / 1-9/16 x 9/16	99262	2.625 x 0.781 / 2-5/8 x 25/32	99452	115 x 20.65 / 115mm x 13/16"
99157	40 x 13mm	99266	68 x 19.05mm / 68mm x 3/4"	99463	4.625 x 1.000 / 4-5/8 x 1
99159	39.85 x 15.88mm / 39.85mm x 5/8"	99269	2.750 x 1.125 / 2-3/4 x 1-1/8"	99465	4.625 x 0.437 / 4-5/8 x 7/16
99162	1.625 x 0.563 / 1-5/8 x 9/16	99272	2.750 x 0.406 / 2-3/4 x 13/32	99472	122 x 19.99mm
99163	41 x 12.7mm / 41mm x 1/2"	99274	2.750 x 0.781 / 2-3/4 x 25/32	99473	120 x 20mm
99165	42.07 x 13.97mm	99275	2.750 x 0.781 / 2-3/4 x 25/32	99491	130.17 x 22mm / 5.125 x 22mm"
99166	41.91 x 11.30mm	99276	70 x 20mm	99492	125 x 26mm
99167	42.88 x 7.95mm / 1-11/16 x 5/16	99281	2.813 x 0.625 / 2-13/16 x 5/8	99494	130 x 19.05mm / 130mm x 3/4"
99168	1.668 x 0.563 / 1-11/16 x 9/16	99284	72 x 19.05mm / 72mm x 3/4"	99498	127 x 17.48mm / 127mm x 11/16"
99169	42 x 14.3mm / 42mm x 9/16"	99287	2.875 x 0.781 / 2-7/8 x 25/32	99499	127 x 20.65mm / 5 x 13/16
99170	44.17 x 9.53mm / 44.17 x 3/8"	99289	2.953 x 0.593 / 2-61/64 x 19/32	99571	145.01 x 19.05mm / 5.709 x 0.750
99171	43.64 x 14.3mm / 43.64mm x 9/16"	99293	2.938 x 0.781 / 2-15/16 x 25/32	99606	154.86 x 26.01mm / 6.096 x 1.024
99172	1.750 x 0.375 / 1-3/4 x 3/8	99294	75 x 22mm		

VA Series V-Ring Seals (Metric)

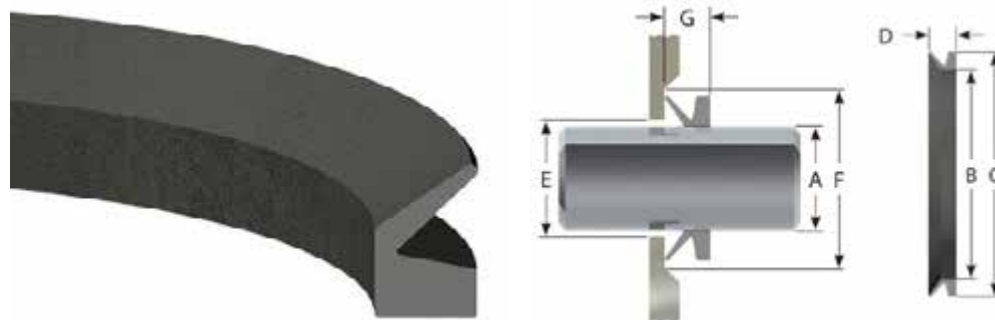

Part Number	Seal Dimensions				Housing Dimensions		
	A	B	C	D	E	F	G
	Shaft Diameter	ID	OD	Height	ID	OD	Width
VA-003	2.70 - 3.50	2.5	5.5	3	A + 1.00	A + 4.00	2.50 ± 0.30
VA-004	3.50 - 4.50	3.2	7.2	3.7	A + 1.00	A + 6.00	3.00 ± 0.40
VA-005	4.50 - 5.50	4	8	3.7	A + 1.00	A + 6.00	3.00 ± 0.40
VA-006	5.50 - 6.50	5	9	3.7	A + 1.00	A + 6.00	3.00 ± 0.40
VA-007	6.50 - 8.00	6	10	3.7	A + 1.00	A + 6.00	3.00 ± 0.40
VA-008	8.00 - 9.50	7	11	3.7	A + 1.00	A + 6.00	3.00 ± 0.40
VA-010	9.50 - 11.50	9	15	5.5	A + 2.00	A + 9.00	4.50 ± 0.60
VA-012	11.50 - 12.50	10.5	16.5	5.5	A + 2.00	A + 9.00	4.50 ± 0.60
VA-013	12.50 - 13.50	11.7	17.5	5.5	A + 2.00	A + 9.00	4.50 ± 0.60
VA-014	13.50 - 15.50	12.5	18.5	5.5	A + 2.00	A + 9.00	4.50 ± 0.60
VA-016	15.50 - 17.50	14	20	5.5	A + 2.00	A + 9.00	4.50 ± 0.60
VA-018	17.50 - 19.00	16	22	5.5	A + 2.00	A + 9.00	4.50 ± 0.60
VA-020	19.00 - 21.00	18	26	7.5	A + 2.00	A + 12.00	6.00 ± 0.80
VA-022	21.00 - 24.00	20	28	7.5	A + 2.00	A + 12.00	6.00 ± 0.80
VA-025	24.00 - 27.00	22	30	7.5	A + 2.00	A + 12.00	6.00 ± 0.80
VA-028	27.00 - 29.00	25	33	7.5	A + 3.00	A + 12.00	6.00 ± 0.80
VA-030	29.00 - 31.00	27	35	7.5	A + 3.00	A + 12.00	6.00 ± 0.80
VA-032	31.00 - 33.00	29	37	7.5	A + 3.00	A + 12.00	6.00 ± 0.80
VA-035	33.00 - 36.00	31	39	7.5	A + 3.00	A + 12.00	6.00 ± 0.80
VA-038	36.00 - 38.00	34	42	7.5	A + 3.00	A + 12.00	6.00 ± 0.80
VA-040	38.00 - 43.00	36	46	9	A + 3.00	A + 15.00	7.00 ± 1.00
VA-045	43.00 - 48.00	40	50	9	A + 3.00	A + 15.00	7.00 ± 1.00
VA-050	48.00 - 53.00	45	55	9	A + 3.00	A + 15.00	7.00 ± 1.00
VA-055	53.00 - 58.00	49	59	9	A + 3.00	A + 15.00	7.00 ± 1.00
VA-060	58.00 - 63.00	54	64	9	A + 3.00	A + 15.00	7.00 ± 1.00
VA-065	63.00 - 68.00	58	68	9	A + 3.00	A + 15.00	7.00 ± 1.00
VA-070	68.00 - 73.00	63	75	11	A + 4.00	A + 18.00	9.00 ± 1.20
VA-075	73.00 - 78.00	67	79	11	A + 4.00	A + 18.00	9.00 ± 1.20
VA-080	78.00 - 83.00	72	84	11	A + 4.00	A + 18.00	9.00 ± 1.20
VA-085	83.00 - 88.00	76	88	11	A + 4.00	A + 18.00	9.00 ± 1.20
VA-090	88.00 - 93.00	81	93	11	A + 4.00	A + 18.00	9.00 ± 1.20
VA-095	93.00 - 98.00	85	97	11	A + 4.00	A + 18.00	9.00 ± 1.20
VA-100	98.00 - 105.00	90	102	11	A + 4.00	A + 18.00	9.00 ± 1.20

Also available in Viton

VA Series V-Ring Seals (Metric)

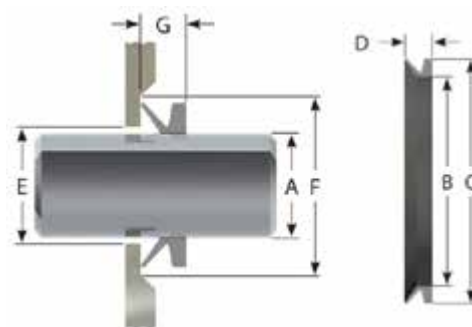

Part Number	Seal Dimensions				Housing Dimensions		
	A	B	C	D	E	F	G
	Shaft Diameter	ID	OD	Height	ID	OD	Width
VA-110	105.00 - 115.00	99	113	12.8	A + 4.00	A + 21.00	10.50 ± 1.50
VA-120	115.00 - 125.00	108	122	12.8	A + 4.00	A + 21.00	10.50 ± 1.50
VA-130	125.00 - 135.00	117	131	12.8	A + 4.00	A + 21.00	10.50 ± 1.50
VA-140	135.00 - 145.00	126	140	12.8	A + 4.00	A + 21.00	10.50 ± 1.50
VA-150	145.00 - 155.00	135	149	12.8	A + 4.00	A + 21.00	10.50 ± 1.50
VA-160	155.00 - 165.00	144	160	14.5	A + 5.00	A + 24.00	12.00 ± 1.80
VA-170	165.00 - 175.00	153	169	14.5	A + 5.00	A + 24.00	12.00 ± 1.80
VA-180	175.00 - 185.00	162	178	14.5	A + 5.00	A + 24.00	12.00 ± 1.80
VA-190	185.00 - 195.00	171	187	14.5	A + 5.00	A + 24.00	12.00 ± 1.80
VA-199	195.00 - 210.00	180	196	14.5	A + 5.00	A + 24.00	12.00 ± 1.80
VA-200	190.00 - 210.00	180	210	25	A + 10.00	A + 45.00	20.00 ± 4.00
VA-220	210.00 - 235.00	198	228	25	A + 10.00	A + 45.00	20.00 ± 4.00
VA-250	235.00 - 265.00	225	255	25	A + 10.00	A + 45.00	20.00 ± 4.00
VA-275	265.00 - 290.00	247	277	25	A + 10.00	A + 45.00	20.00 ± 4.00
VA-300	290.00 - 310.00	270	300	25	A + 10.00	A + 45.00	20.00 ± 4.00
VA-325	310.00 - 335.00	292	322	25	A + 10.00	A + 45.00	20.00 ± 4.00
VA-350	335.00 - 365.00	315	345	25	A + 10.00	A + 45.00	20.00 ± 4.00
VA-375	365.00 - 390.00	337	367	25	A + 10.00	A + 45.00	20.00 ± 4.00
VA-400	390.00 - 430.00	360	390	25	A + 10.00	A + 45.00	20.00 ± 4.00
VA-450	430.00 - 480.00	405	435	25	A + 10.00	A + 45.00	20.00 ± 4.00
VA-500	480.00 - 530.00	450	480	25	A + 10.00	A + 45.00	20.00 ± 4.00
VA-550	530.00 - 580.00	495	525	25	A + 10.00	A + 45.00	20.00 ± 4.00
VA-600	580.00 - 630.00	540	570	25	A + 10.00	A + 45.00	20.00 ± 4.00

Also available in Viton

VS Series V-Ring Seals (Metric)

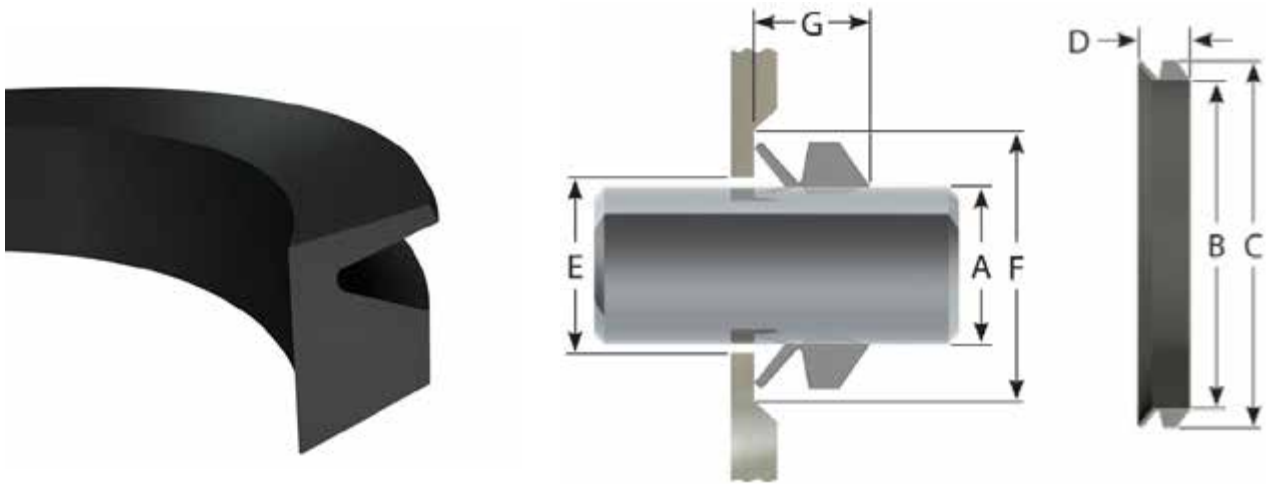

Part Number	Seal Dimensions				Housing Dimensions		
	A	B	C	D	E	F	G
	Shaft Diameter	ID	OD	Height	ID	OD	Width
VS-005	4.50 - 5.50	4	8	5.2	A + 1.00	A + 6.00	4.50 ± 0.40
VS-006	5.50 - 6.50	5	9	5.2	A + 1.00	A + 6.00	4.50 ± 0.40
VS-007	6.50 - 8.00	6	10	5.2	A + 1.00	A + 6.00	4.50 ± 0.40
VS-008	8.00 - 9.50	7	11	5.2	A + 1.00	A + 6.00	4.50 ± 0.40
VS-010	9.50 - 11.50	9	15	7.7	A + 2.00	A + 9.00	6.70 ± 0.60
VS-012	11.50 - 13.50	10.5	16.5	7.7	A + 2.00	A + 9.00	6.70 ± 0.60
VS-014	13.50 - 15.50	12.5	18.5	7.7	A + 2.00	A + 9.00	6.70 ± 0.60
VS-016	15.50 - 17.50	14	20	7.7	A + 2.00	A + 9.00	6.70 ± 0.60
VS-018	17.50 - 19.00	16	22	7.7	A + 2.00	A + 9.00	6.70 ± 0.60
VS-020	19.00 - 21.00	18	26	10.5	A + 2.00	A + 12.00	9.00 ± 0.80
VS-022	21.00 - 24.00	20	28	10.5	A + 2.00	A + 12.00	9.00 ± 0.80
VS-025	24.00 - 27.00	22	30	10.5	A + 2.00	A + 12.00	9.00 ± 0.80
VS-028	27.00 - 29.00	25	33	10.5	A + 3.00	A + 12.00	9.00 ± 0.80
VS-030	29.00 - 31.00	27	35	10.5	A + 3.00	A + 12.00	9.00 ± 0.80
VS-032	31.00 - 33.00	29	37	10.5	A + 3.00	A + 12.00	9.00 ± 0.80
VS-035	33.00 - 36.00	31	39	10.5	A + 3.00	A + 12.00	9.00 ± 0.80
VS-038	36.00 - 38.00	34	42	10.5	A + 3.00	A + 12.00	9.00 ± 0.80
VS-040	38.00 - 43.00	36	46	13	A + 3.00	A + 15.00	11.00 ± 1.00
VS-045	43.00 - 48.00	40	50	13	A + 3.00	A + 15.00	11.00 ± 1.00
VS-050	48.00 - 53.00	45	55	13	A + 3.00	A + 15.00	11.00 ± 1.00

Also available in Viton

VS Series V-Ring Seals (Metric)

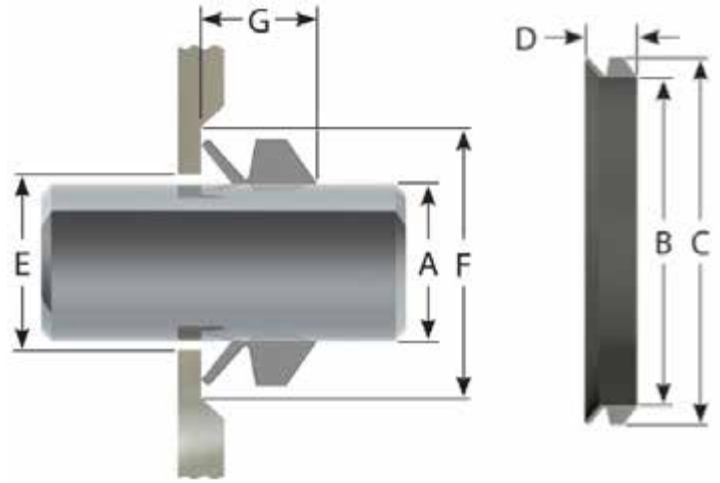
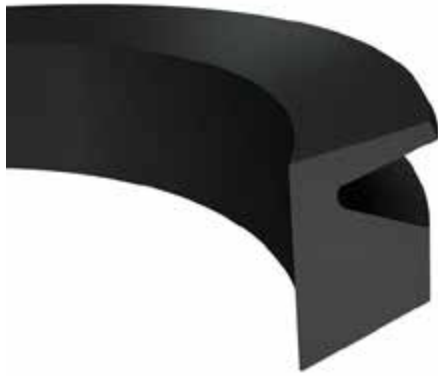

Part Number	Seal Dimensions				Housing Dimensions		
	A	B	C	D	E	F	G
	Shaft Diameter	ID	OD	Height	ID	OD	Width
VS-055	53.00 - 58.00	49	59	13	A + 3.00	A + 15.00	11.00 ± 1.00
VS-060	58.00 - 63.00	54	64	13	A + 3.00	A + 15.00	11.00 ± 1.00
VS-065	63.00 - 68.00	58	68	13	A + 3.00	A + 15.00	11.00 ± 1.00
VS-070	68.00 - 73.00	63	75	15.5	A + 4.00	A + 18.00	13.50 ± 1.20
VS-075	73.00 - 78.00	67	79	15.5	A + 4.00	A + 18.00	13.50 ± 1.20
VS-080	78.00 - 83.00	72	84	15.5	A + 4.00	A + 18.00	13.50 ± 1.20
VS-085	83.00 - 88.00	76	88	15.5	A + 4.00	A + 18.00	13.50 ± 1.20
VS-090	88.00 - 93.00	81	93	15.5	A + 4.00	A + 18.00	13.50 ± 1.20
VS-095	93.00 - 98.00	85	97	15.5	A + 4.00	A + 18.00	13.50 ± 1.20
VS-100	98.00 - 105.00	90	102	15.5	A + 4.00	A + 18.00	13.50 ± 1.20
VS-110	105.00 - 115.00	99	113	18	A + 4.00	A + 21.00	15.50 ± 1.50
VS-120	115.00 - 125.00	108	122	18	A + 4.00	A + 21.00	15.50 ± 1.50
VS-130	125.00 - 135.00	117	131	18	A + 4.00	A + 21.00	15.50 ± 1.50
VS-140	135.00 - 145.00	126	140	18	A + 4.00	A + 21.00	15.50 ± 1.50
VS-150	145.00 - 155.00	135	149	18	A + 4.00	A + 21.00	15.50 ± 1.50
VS-160	155.00 - 165.00	144	160	20.5	A + 5.00	A + 24.00	18.00 ± 1.80
VS-170	165.00 - 175.00	153	169	20.5	A + 5.00	A + 24.00	18.00 ± 1.80
VS-180	175.00 - 185.00	162	178	20.5	A + 5.00	A + 24.00	18.00 ± 1.80
VS-190	185.00 - 195.00	171	187	20.5	A + 5.00	A + 24.00	18.00 ± 1.80
VS-199	195.00 - 210.00	180	196	20.5	A + 5.00	A + 24.00	18.00 ± 1.80

Also available in Viton

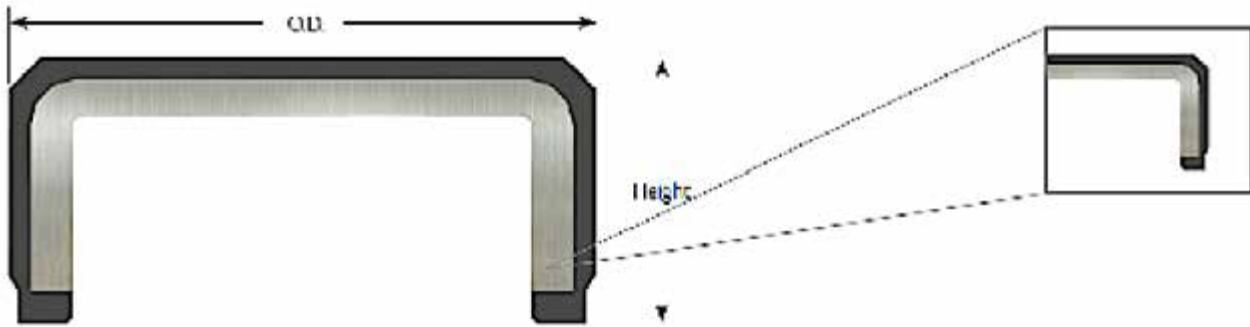

VK Seals (OD x Height mm)

VK-16 x 4	VK-32 x 8	VK-47 x 7	VK-68 x 8	VK-92 x 10	VK-160 x 15
VK-20 x 4	VK-32 x 9.5	VK-47 x 10	VK-70 x 10	VK-95 x 10	VK-170 x 15
VK-22 x 5	VK-35 x 8	VK-50 x 7	VK-72 x 9	VK-100 x 12	VK-180 x 12
VK-22 x 7	VK-37 x 7	VK-52 x 6.5	VK-75 x 7	VK-110 x 12	VK-190 x 12
VK-24 x 7	VK-37 x 10	VK-52 x 7	VK-80 x 10	VK-120 x 12	VK-200 x 13
VK-25 x 7	VK-40 x 7	VK-52 x 10	VK-80 x 12	VK-125 x 12	VK-225 x 14
VK-26 x 6.5	VK-42 x 7	VK-55 x 10	VK-85 x 12	VK-130 x 12	VK-240 x 15
VK-28 x 7	VK-42 x 9.5	VK-62 x 7	VK-90 x 8	VK-140 x 15	VK-260 x 15
VK-30 x 8	VK-45 x 7	VK-62 x 8	VK-90 x 10	VK-145 x 12	VK-290 x 15
VK-32 x 7	VK-47 x 6.5	VK-65 x 8	VK-90 x 12	VK-150 x 15	